



DUCATI 1098R

(2008)

EVOLUTION EXHAUST SYSTEM

www.akrapovic.net

The Ducati 1098R and the Akrapovic Evolution exhaust system are a fantastic combination of our years of experience at the highest level of motorcycle racing and precise handcrafting. The Akrapovic Evolution open system releases the maximum amount of power and torque, and serious riders will be able to maximize the bike's potential on the race track. In addition to performance, the Evolution system comes in a full titanium configuration, showing a clean racing look. Of course there is also a much more powerful sound coming out of the two underseat mufflers. You will also save 3.79 kg compared to the stock Ducati exhaust system. The system is for race and track days only and is not homologated for road use.

PERFORMANCE

Measurements of the Akrapovic EVOLUTION system on the DUCATI 1098R without muffler insert:

Power & Torque: the Akrapovic Evolution open system greatly increases the potential of the big twin cylinder engine. Both power and torque are increased over the entire rpm range, with the greatest increase shown in the middle and top of the range. We measured an incredible 175.5 HP at 10100 rpm, while the max. increased power of 9.7 HP was measured at 10100 rpm.

CONFIGURATION

The Akrapovic EVOLUTION open system for Ducati 1098R has a specific 2-1-2 configuration. System has conical header tubes, collector and link pipes, all of which are all made of titanium. The header tubes, collector, link pipe and muffler connections are attached with sleeve joints, secured with silicon-shielded springs. The muffler is available with a titanium or carbon fiber outer sleeve. The metal interior parts of both mufflers are made entirely of titanium. The outlet cap is made from carbon fiber in both cases. The system has a welded fitting on the link pipe for attaching the lambda sensor. The mufflers are attached to the motorcycle with pair of carbon fiber clamps.

	PERFORMANCE		
	stock	AKRAPOVIC	max. increased power
max. rear wheel power HP / rpm (measured on Dynojet ATV)	166.5 / 9850	175.5 / 10100	9.7 / 10100

	CONFIGURATION		
	header tubes	collector	link pipe
material	S.S.	Ti	Ti
tube shape	Conical	Cylindrical	Conical

interference crossover tubes	-	lambda sensor	YES	
header tube inner sleeves	-	header tube flanges	WELDED ON HEADERS	
header tubes - collector connection	SLEEVE JOINT + SILICON SHIELDED SPRINGS	collector / header tube - link pipe connection	SLEEVE JOINT + SILICON SHIELDED SPRINGS	
link pipe - muffler connection	SLEEVE JOINT + SILICON SHIELDED SPRINGS	muffler inlet cap /outlet cap	Ti / Carb.-fiber	
muffler metal interior	TITANIUM	muffler outer sleeve	Ti / Carb.-fiber	
muffler clamp	CARBON-FIBER	muffler bracket	NO	
muffler insert	EU	NOISE DAMPER	heat shield	YES - Carb.-fiber
	US	-	catalytic converter	NO

	ADDITIONAL DATA				
	stock	AKRAPOVIC		difference	
weight comparison (kg)	9.55	racing	evolution	stock - racing	stock - evolution
		-	5.76	-	3.79
noise measurements (dB / rpm)	stock		AKRAPOVIC		
	96dB / 4875		101.5dB / 4875		
possibility of periodic service without removing A.E.S.	oil		oil filter		
	YES		YES		
legal for street use	NO				

Technical specifications of Akrapovic exhaust systems and related products subject to change without notice.



Product code: (109190) S-D10EFT3T-ZC, (109189) S-D10EFT3T-ZT
(108370) S-D10EFT2T-ZT/1 evo. headers + street legal slip-on exhaust

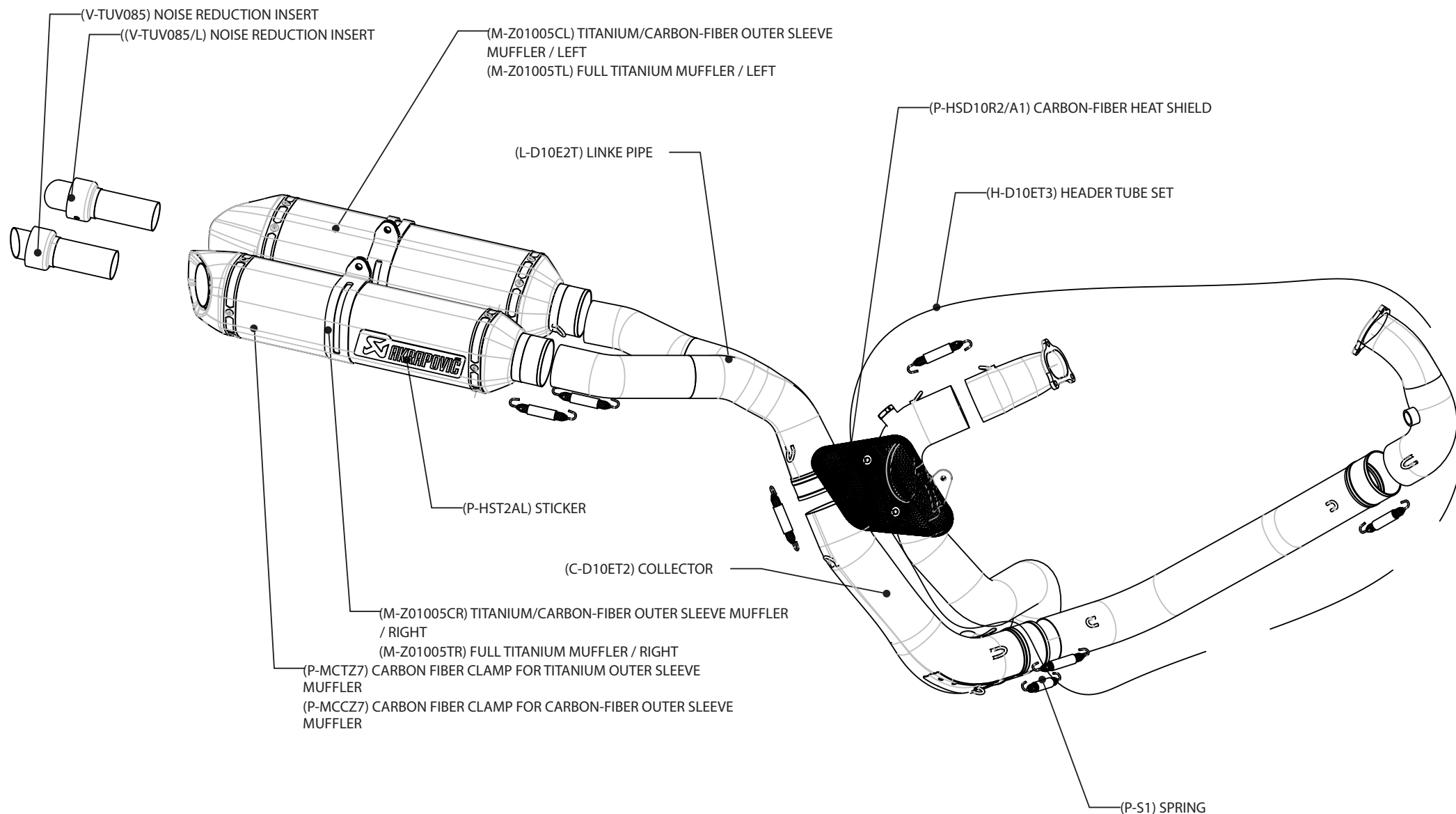

Product code: (109190) S-D10EFT3T-ZC, (109189) S-D10EFT3T-ZT
 (108370) S-D10EFT2T-ZT/1 evo. headers + street legal slip-on exhaust



EVOLUTION LINE tube set and a street legal SLIP-ON muffler.
 Warning! This combination is not homologated!

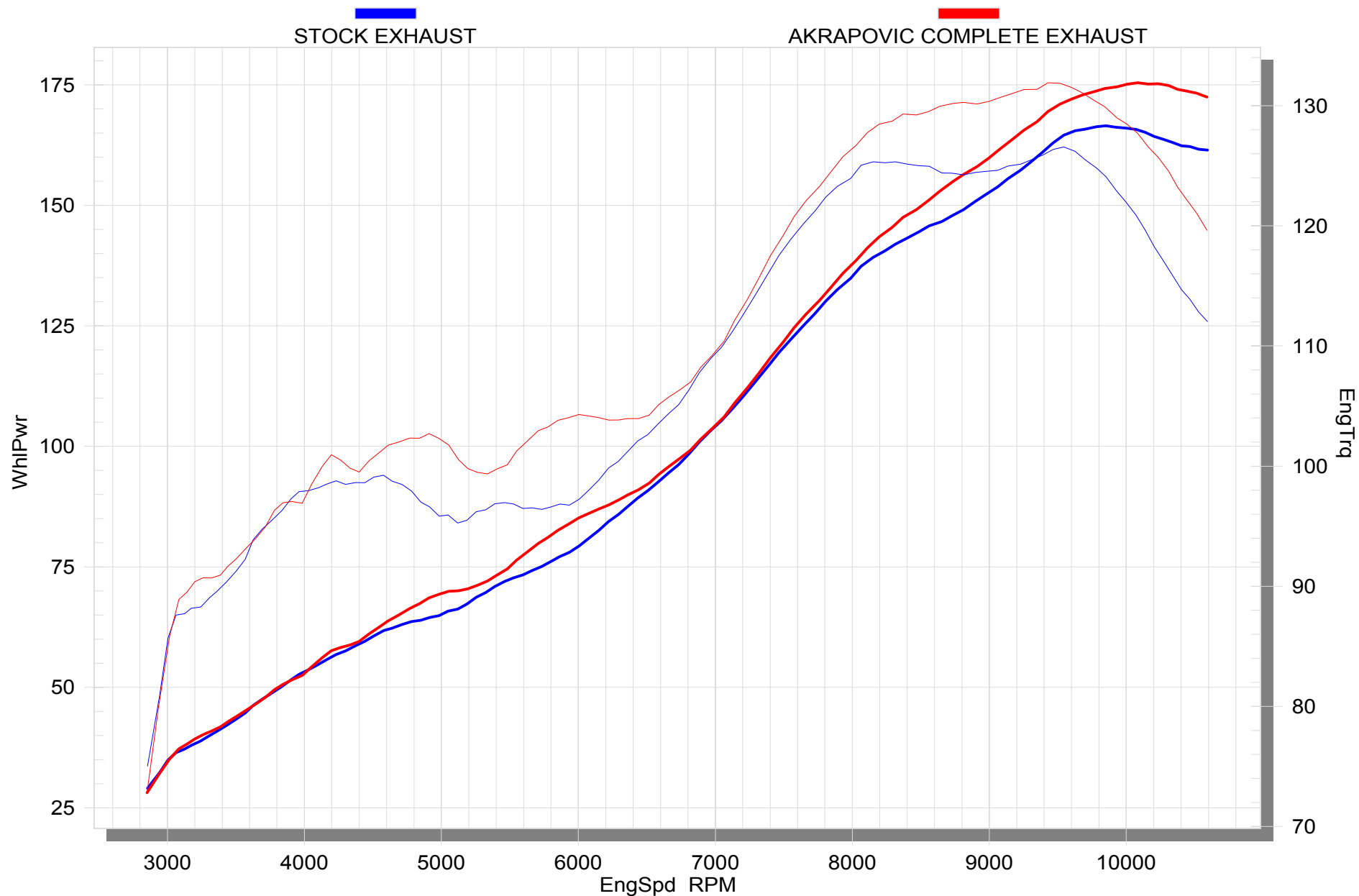

Product code: (109190) S-D10EFT3T-ZC, (109189) S-D10EFT3T-ZT
 (108370) S-D10EFT2T-ZT/1 evo. headers + street legal slip-on exhaust