



Honda CRF 450 R (2005)

Slip-On Exhaust System

Akrapovic Slip-On Exhaust System

for the Honda CRF 450 R (2005)

The Akrapovic SLIP-ON system is a starting-level tuning component, and is intended mainly for amateur MX riders. It is an excellent combination of price, performance, top-quality materials and production quality. The system conforms to FIM MX regulations for exhaust system noise levels, as it has a 98 dB noise damper installed, which can be replaced with a 94 dB FIM Enduro noise damper for those who like to ride both MX and enduro. For the US market systems come with an approved spark arrester. 2005 stock power delivery is slightly lower than the 2004 model, which is therefore reflected in the 2005 Akrapovic power delivery figures.

PERFORMANCE

Measurements of the Akrapovic SLIP-ON system on the HONDA CRF 450 R (without muffler insert):

Power: the Akrapovic SLIP-ON exhaust system does what it is meant to do. The power increase is substantial and runs all the way to 7000 rpm, where there is a slight decrease for about 800 rpm. At 7800 rpm the increase appears again and continues into the overrev range. At 8440 rpm we obtained an even better result with the FIM MX noise damper than with an open exhaust.

Torque: with the SLIP-ON system the stock torque curve is increased from 4000 rpm on, and like the power curve, the increase runs into the overrev range. In contrast to the stock curve, our highest values occur over a longer range and are less peaky, which means that peak torque levels are available for a longer time.

CONFIGURATION

The Akrapovic SLIP-ON system for the Honda CRF is made of a titanium muffler and a stainless steel link pipe welded together. The link pipe has cylindrical tubing. At the other end, the link pipe is attached to the header assembly with a free-floating joint, secured with a metal clamp. The muffler is attached with an Akrapovic Offroad carbon-fiber clamp. The muffler outer sleeve is made of titanium, with a 98 dB noise damper which conforms to FIM MX regulations for exhaust system noise levels. For the US market systems come with an approved spark arrester, which is also laser engraved on the muffler.

OPTIONS

For riders who enjoy both MX and Enduro riding, the Akrapovic SLIP-ON exhaust system is also available with a 94 dB FIM enduro damper which conforms to FIM Enduro regulations for exhaust system noise levels.

| | PERFORMANCE | | |
|---|-------------|---|---|
| | stock | AKRAPOVIC | max. increased power |
| max. rear wheel power HP / rpm (measured on SuperFlow Cyle Dyn) | 49 / 8450 | 49.1/8440 (without noise damper) 49.1/8440 (FIM MX noise damper) | 1.2 / 4600 (without noise damper) 1 / 8200 (FIM MX noise damper) |

| | CONFIGURATION | | |
|------------|---------------|-----------|-----------------|
| | header tubes | collector | link pipe |
| material | - | - | STAINLESS STEEL |
| tube shape | - | - | CYLINDRICAL |

| | | | |
|-------------------------------------|--|--|-----------------------------|
| interference crossover tubes | - | lambda sensor | - |
| header tube inner sleeves | - | header tube flanges | - |
| header tubes - collector connection | - | collector / header tube - link pipe connection | FREE FLOATING + METAL CLAMP |
| link pipe - muffler connection | WELDED | muffler inlet cap /outlet cap | STAINLESS STEEL / TITANIUM |
| muffler metal interior | STAINLESS STEEL | muffler outer sleeve | TITANIUM |
| muffler insert | 1x CARBON-FIBER OFF ROAD | muffler bracket | - |
| noise damper | FIM MX 98 dB (EU market) SPARK ARRESTER (US market) | heat shield | - |

| OPTIONS | | | |
|-----------|------------------|-----------------|-------------|
| link pipe | noise damper | muffler bracket | heat shield |
| - | FIM ENDURO 94 dB | - | - |

| | ADDITIONAL DATA | | | | |
|------------------------|-----------------|----------------|--------------------|--------------|------------------|
| | stock | AKRAPOVIC | | difference | |
| | | S.S. link pipe | TITANIUM link pipe | stock - S.S. | stock - TITANIUM |
| weight comparison (kg) | 2.65 | 2.19 | - | 0.46 | - |

| | | |
|---|-----------|---|
| noise measurements (dB / rpm) | stock | AKRAPOVIC |
| | 98 / 4500 | 94 / 4500 (FIM ENDURO) 98 / 4500 (FIM MX) 102 / 4500 (without noise damper) |
| possibility of periodic service without removing A.E.S. | oil | oil filter |
| | YES | YES |
| legal for street use | NO | |

Technical specifications of Akrapovic exhaust systems and related products subject to change without notice.

Akrapovic Slip-On Exhaust System for the Honda CRF 450 R (2005)



FIM ENDURO 94 dB
NOISE DAMPER



ANTI-SEIZE LEAD-FREE
COPPER PASTE



CARBON-FIBER
MUFFLER CLAMP

Off-Road
Program

Product code: 103504 (S-H4SO3-MT) EU market
104084 (S-H4SO3-MTA) US market

Akrapovic Slip-On Exhaust System for the Honda CRF 450 R (2005)

Akrapovic Exhaust System Technology copyright 2004, all rights reserved



Off-Road
Program

Product code: 103504 (S-H4SO3-MT) EU market
104084 (S-H4SO3-MTA) US market

Akrapovic Slip-On Exhaust System

for the Honda CRF 450 R (2005)



Akrapovic Exhaust System Technology copyright 2004, all rights reserved

Off-Road Program

Product code: 103504 (S-H4SO3-MT) EU market
104084 (S-H4SO3-MTA) US market

Akrapovic Slip-On Exhaust System for the Honda CRF 450 R (2005)

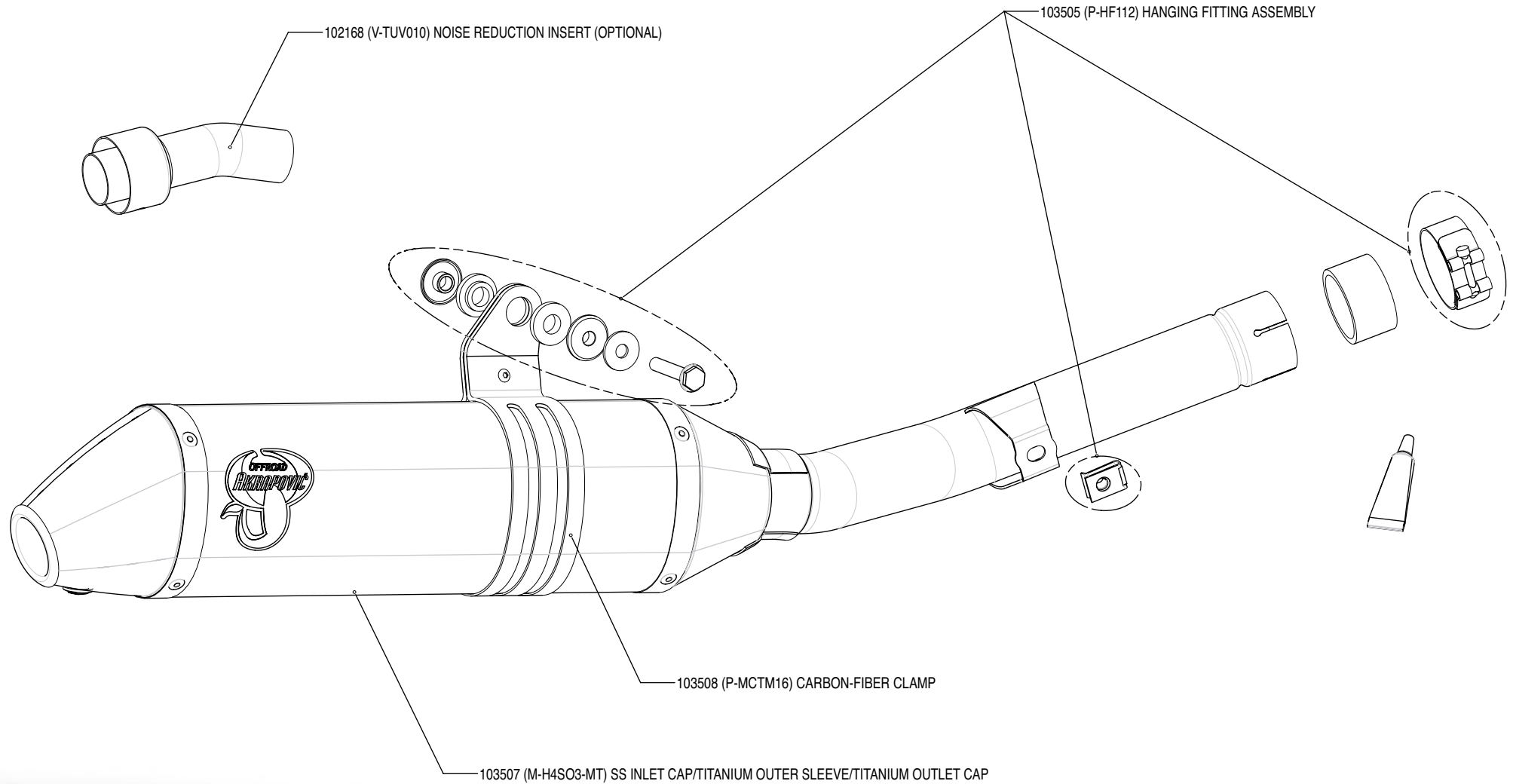

Akrapovic Exhaust System Technology copyright 2004, all rights reserved

Off-Road
Program

Product code: 103504 (S-H4SO3-MT) EU market

Akrapovic Slip-On Exhaust System for the Honda CRF 450 R (2005)

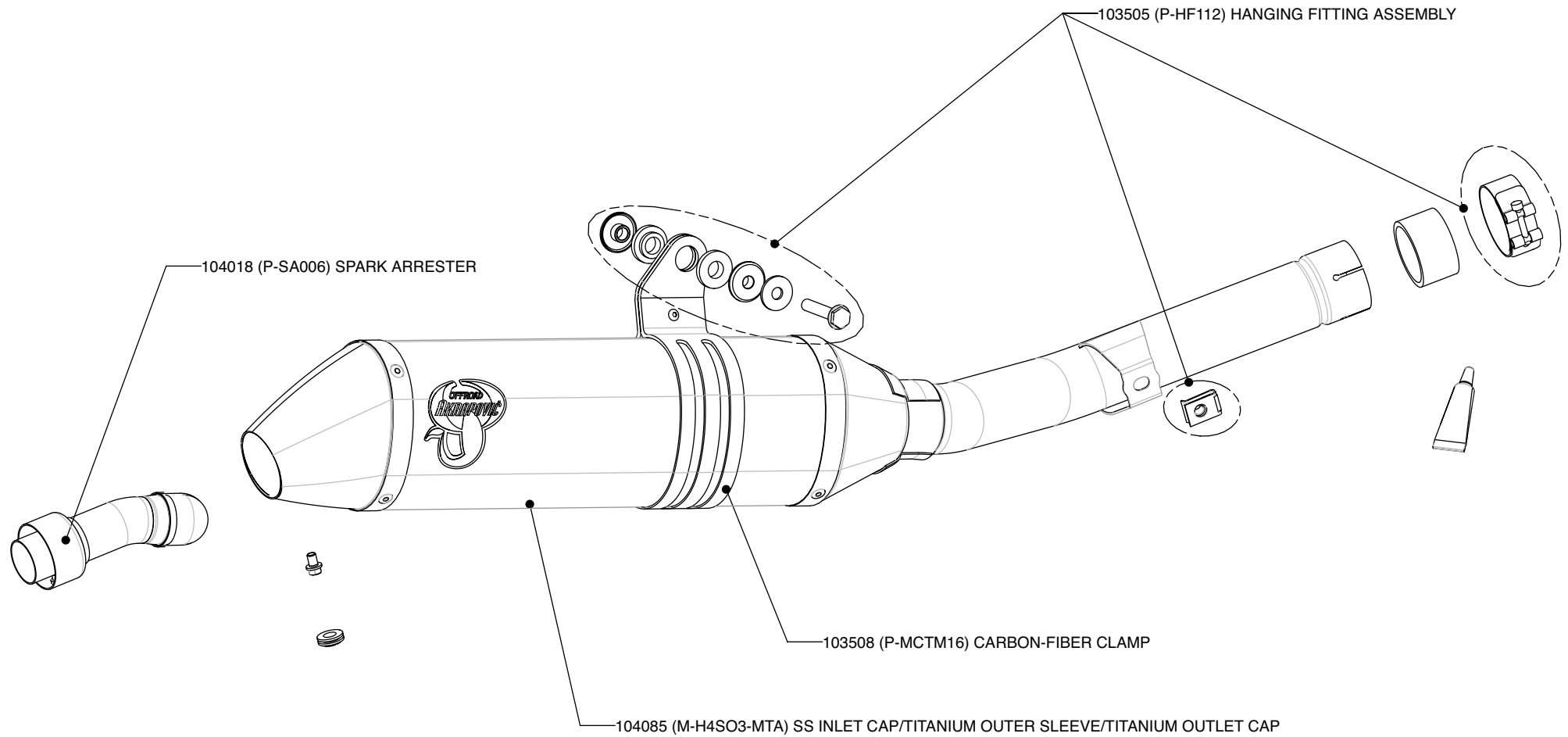

Akrapovic Exhaust System Technology copyright 2004, all rights reserved

Off-Road
Program

Product code: 104084 (S-H4SO3-MTA) US market

Akrapovic Slip-On Exhaust System

for the Honda CRF 450 R (2005)

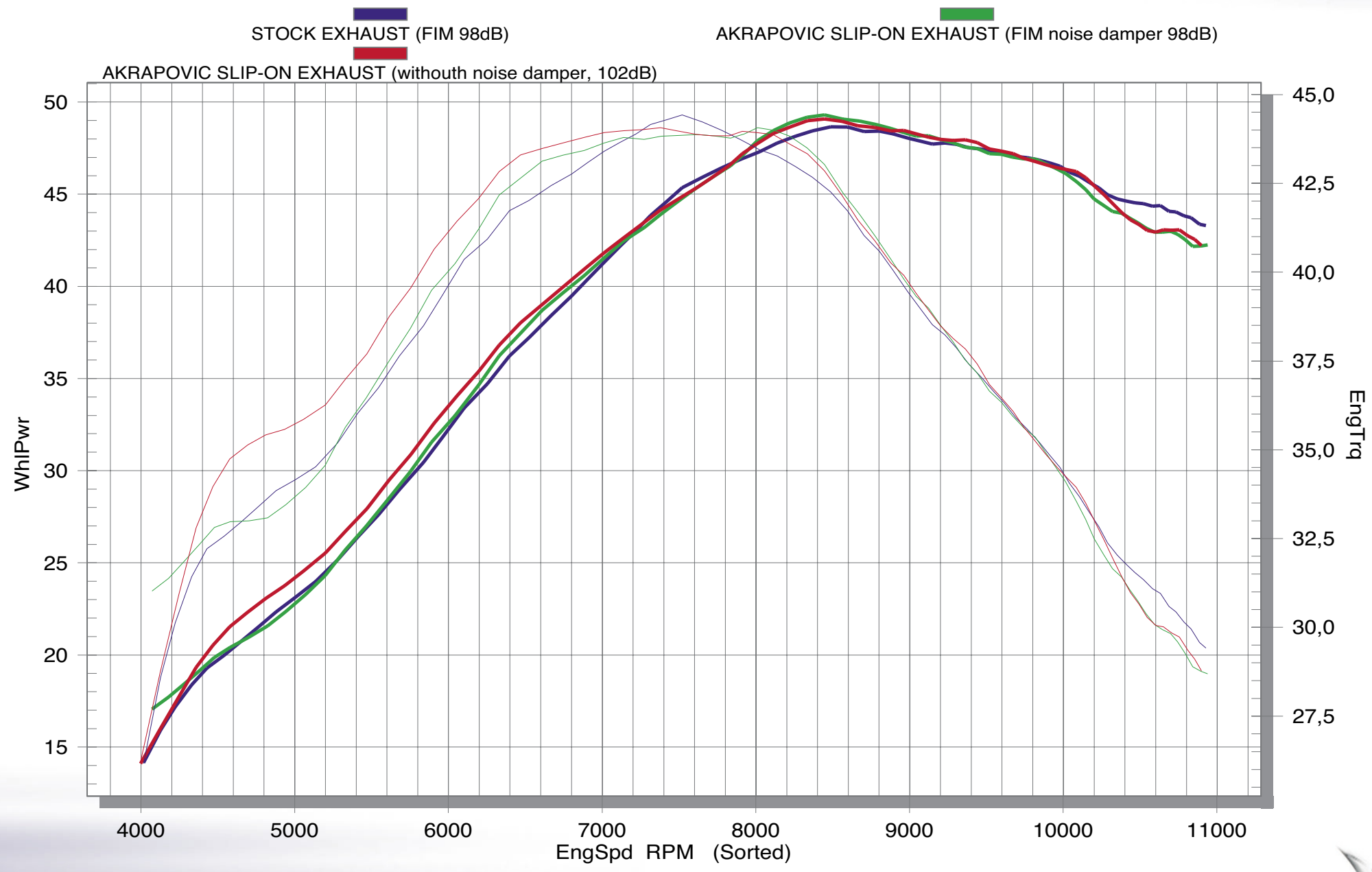

Off-Road Program

Product code: 103504 (S-H4SO3-MT) EU market
104084 (S-H4SO3-MTA) US market



Akrapovic Exhaust System Technology copyright 2004, all rights reserved