

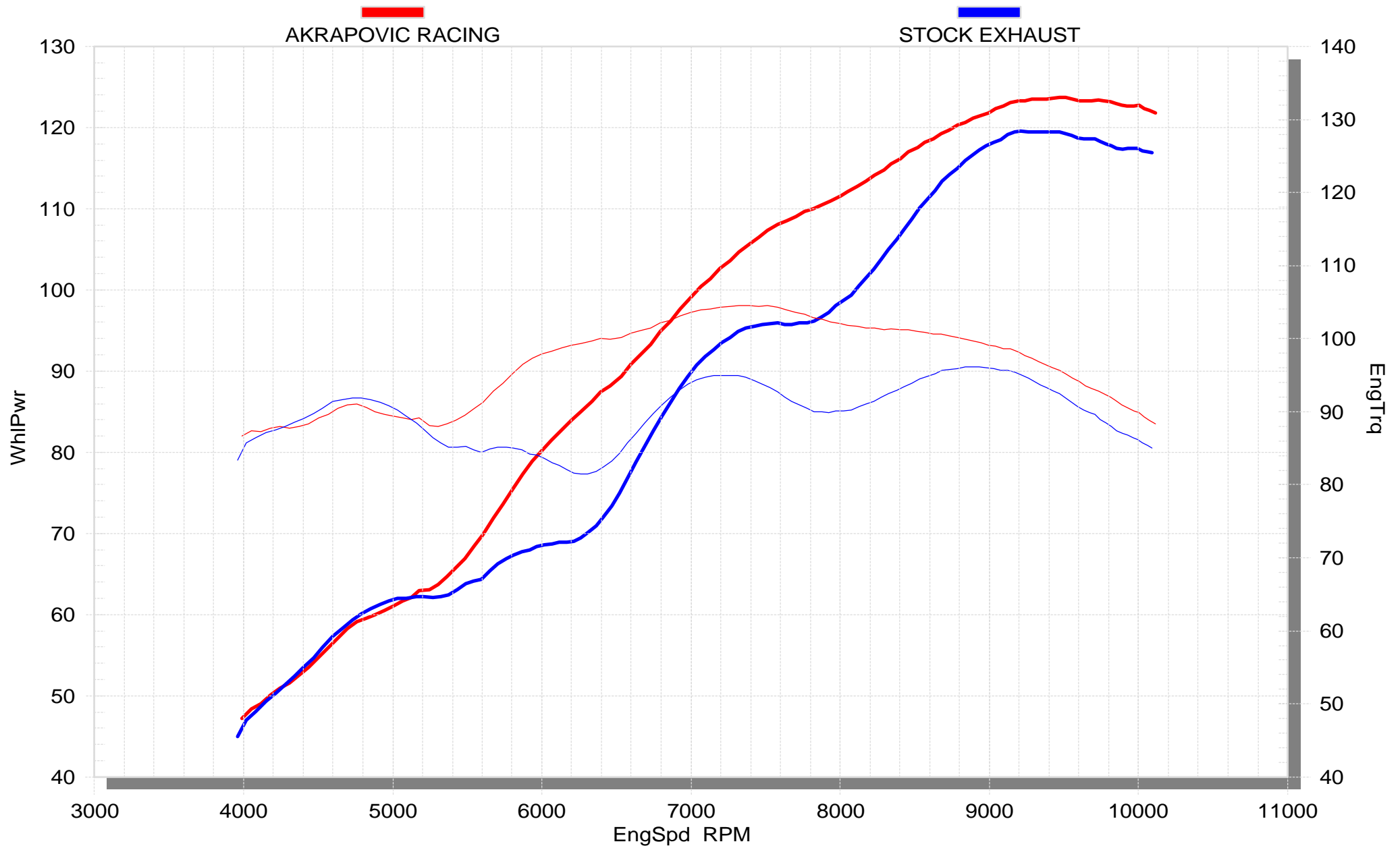

APRILIA RSV MILLE 2-2 RACING

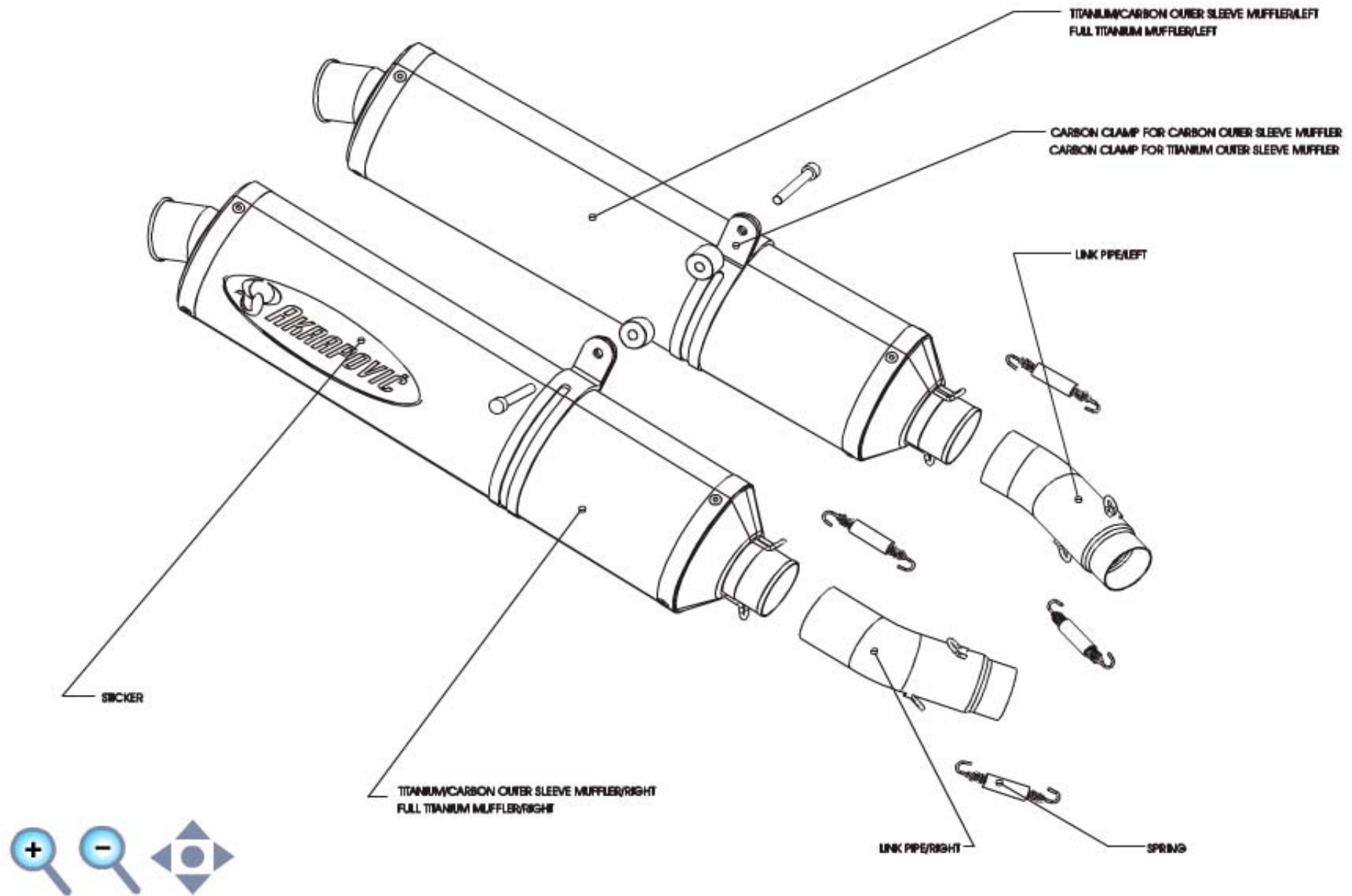



APRILIA SL 1000 FALCO / R (2000 - 2005) AKRAPOVIC SLIP-ON LINE

The Aprilia Falco is a slightly more moderate version of the Aprilia RSV, in terms of both performance and styling. It was not designed for setting lap times or pushing the physical envelope, but for enjoyable sport touring alone or in pairs. Its extremely attractive styling is well suited to its purpose. It lies somewhere between a sport touring bike and a naked.

GOAL

The dominant element of the interesting lines of the Falco is definitely its highly visible split frame. The double theme is repeated in the taillights, the exhaust system etc. In order to provide customers the chance to upgrade the performance of their bikes without spoiling the looks, we have designed a dual Akrapovic SLIP-ON exhaust system. This system gives the Falco an even bolder look, a much more powerful sound and a nice boost in performance.

ABOUT AKRAPOVIC SLIP-ON SYSTEM

An Akrapovic SLIP-ON system is basically made of a muffler and a link pipe. Of course there are lots of other elements which make up the entire package. The cylindrical link pipe is made of high-quality stainless steel. It is attached with floating connections to the muffler on one end and to the stock header assembly on the other. Both of these connections are secured with the use of high-quality silicon-shielded springs.

The muffler, or we should say mufflers, as the Aprilia has one on each side, are the characteristic Akrapovic oval. As opposed to some of our competitors, the interiors of our mufflers are made entirely of titanium. The outer sleeves of the mufflers are available in either the dark shine of carbon-fiber or the elegant satin sheen of titanium. The choice is yours. They are mounted in the standard position, which means that they are mounted to the stock chassis hanging bracket with the help of the renowned Akrapovic carbon-fiber muffler clamp.

NOTE: Mufflers are attached to the stock chassis hanging brackets by a carbon-fiber clamps together with an appropriately dimensioned aluminum spacers and bolts.

(LEFT MUFFLER: spacer 21 mm & inbus M8x 70, RIGHT MUFFLER: spacer 16 mm & inbus M8x 60)

Measured performance of the Akrapovic SLIP-ON system:

POWER

the power curve clearly shows the fluctuation of the stock engine, which is a specific characteristic of the two-cylinder motor and the slightly altered electronics, as the motor is based on the RSV motor readjusted for the Falco. This also makes it more difficult to limit the substantial oscillations of the stock engine.

The main advantage of the Akrapovic SLIP-ON system is the increase in power throughout the entire rpm range. We were able to accomplish this despite the specific characteristics of the stock engine. The maximum increase is seen at the top of the range and also in the middle, which is very appropriate for comfortable everyday use.

TORQUE

the characteristic of the engine to fluctuate in power delivery is also evident in the torque curve. However, we managed to improve the curve, especially from 4000 rpm on, which is quite suitable to the sport touring nature of the bike.

The Akrapovic SLIP-ON system is a product of years of experience in the field of motorcycle exhaust systems development. This includes feedback from factory and private racing teams all over the world. Extreme racing conditions are without a doubt the best test of the quality and superior design of Akrapovic exhaust systems, which only improve from year to year.

When you hold the Akrapovic SLIP-ON system in your hands, you will be amazed at how light it is. Our system delivers a 5.9 kg weight savings over the stock system. That's right – 5.9 kg! That is a lot of weight not to have to carry during maneuvering. And, as mentioned above, the sound is going to get a lot of people's attention. The Akrapovic SLIP-ON system for the Aprilia Falco is an excellent choice and a great combination of high quality, a renowned brand name, aesthetic perfection and affordability.

[Exclusion of Certain Liability](#) ▶

AVAILABLE SLIP-ON OPTIONS:

PRODUCT CODE:	DESCRIPTION:		
S-A10SO3-C	APRILIA SL 1000 FALCO/R , 00-05 ; SLIP-ON SYSTEM Link pipe's & M-TCR1 titanium/carbon muffler's L/R & clamp's C2		
S-A10SO3-T	APRILIA SL 1000 FALCO/R , 00-05 ; SLIP-ON SYSTEM Link pipe's & M-TTR1 full titanium muffler's L/R & clamp's T2		
TECHNICAL DATA	stock	akrapovic	difference
weight measurments	9.30 kg	3.40 kg	5.90 kg
power measurments	106.5 HP / 9400 rpm	109 HP / 9500 rpm	4.8 HP / 10200 rpm*
noise mesurments	91db / 4625 rpm	97.3 db / 4625 rpm	6.3 db / 4250 rpm
legal for street use	NO		

***MAXIMUM MEASURED POWER DIFFERENCE**

[more about Slip-on line](#) ▶

For any price information please contact your local [dealer / importer](#).

