



Honda Hornet 900 (2002, 2003)

Slip-On SP Series Exhaust System

# Akrapovic Slip-On SP Series Exhaust System

for the Honda Hornet 900 (2002, 2003)

Since the bike is intended for a wide spectrum of riders with its racy looks and dynamic character, we also took accessibility of the product into account. Therefore we have developed an Akrapovic SLIP-ON SP SERIES system which is a great combination of quality, aesthetics, performance and price. Beside this the system is also street legal approved. Our system will definitely add to the attractive lines of your Honda Hornet 900.

## PERFORMANCE

Measurements of the Akrapovic SLIP-ON SP SERIES system on the Honda Hornet 900 (without noise damper):

Power: although our SLIP-ON systems are developed in order to improve aesthetics and sound, the performance of these systems also reflects the level of quality and know-how at our company. With the Akrapovic SLIP-ON system the power curve of the Honda Hornet 900 is improved throughout the rpm range, with a steeper response angle and additional power right at the top of the range.

Torque: the torque also does not remain at the stock level. Even more than with power, the torque curve demonstrates the success of the Akrapovic SLIP-ON system. The entire curve is higher and wider, and the drop-out at around 5800 rpm (right in the middle of the rpm range) is flattened, making this a system which will be highly prized by riders.

## CONFIGURATION

Akrapovic SLIP-ON systems are composed of two main elements, a link pipe and a muffler. The link pipe is conical and made of stainless steel. In the case of the Honda Hornet 900, the joint where the two main elements meet is made with a flawless weld. Since the mufflers are mounted high, to the left and right of the seat, the configuration also called for the use of a special carbon-fiber heat shield.

The mufflers of Akrapovic SLIP-ON system are attached to the bike with a carbon-fiber clamp in the same place as the stock clamp, while the Akrapovic system is joined to the stock header assembly with a floating connection and secured with a metal clamp. The muffler is the familiar Akrapovic oval, which is available in titanium outer sleeve. All metal parts in the interior of the muffler are made of stainless steel.

	PERFORMANCE		
	stock	AKRAPOVIC	max. increased power
max. rear wheel power HP / rpm (measured on SuperFlow Cycle Dyn)	99 / 9290	101.5 / 9330	4.2 / 7200

	CONFIGURATION		
	header tubes	collector	link pipe
material	-	-	STAINLESS STEEL
tube shape	-	-	CONICAL

interference crossover tubes	-	lambda sensor	-
header tube inner sleeves	-	header tube flanges	-
header tubes - collector connection	-	collector / header tube - link pipe connection	FREE-FLOATING + METAL CLAMP
link pipe - muffler connection	WELDED	muffler inlet cap / outlet cap	STAINLESS STEEL / STAINLESS STEEL
muffler metal interior	STAINLESS STEEL	muffler outer sleeve	TITANIUM
muffler clamp	2x CARBON-FIBER ROAD	muffler bracket	-
noise damper	HOMOLOGATED	heat shield	CARBON-FIBER

OPTIONS				
link pipe	noise damper	muffler outer sleeve	muffler bracket	heat shield
-	-	-	-	-

	ADDITIONAL DATA				
	stock	AKRAPOVIC		difference	
weight comparison (kg)	8.00	S.S. link pipe	TITANIUM link pipe	stock - S.S.	stock - titanium
		-	-	-	-
noise measurements (dB / rpm)	stock		AKRAPOVIC		
	85 / 4500		95 / 4500		
possibility of periodic service without removing A.E.S.	oil		oil filter		
	YES		YES		
legal for street use	YES				

Technical specifications of Akrapovic exhaust systems and related products subject to change without notice.

# Akrapovic Slip-On SP Series Exhaust System for the Honda Hornet 900 (2002, 2003)



CARBON-FIBER  
MUFFLER CLAMPS

Road  
Program

Product code: 102337 (SS-H9SO1-HDT)



Akrapovic Exhaust System Technology copyright 2004, all rights reserved

# Akrapovic Slip-On SP Series Exhaust System for the Honda Hornet 900 (2002, 2003)



Akrapovic Exhaust System Technology copyright 2004, all rights reserved

Road  
Program

Product code: 102337 (SS-H9SO1-HDT)

# Akrapovic Slip-On SP Series Exhaust System

for the Honda Hornet 900 (2002, 2003)

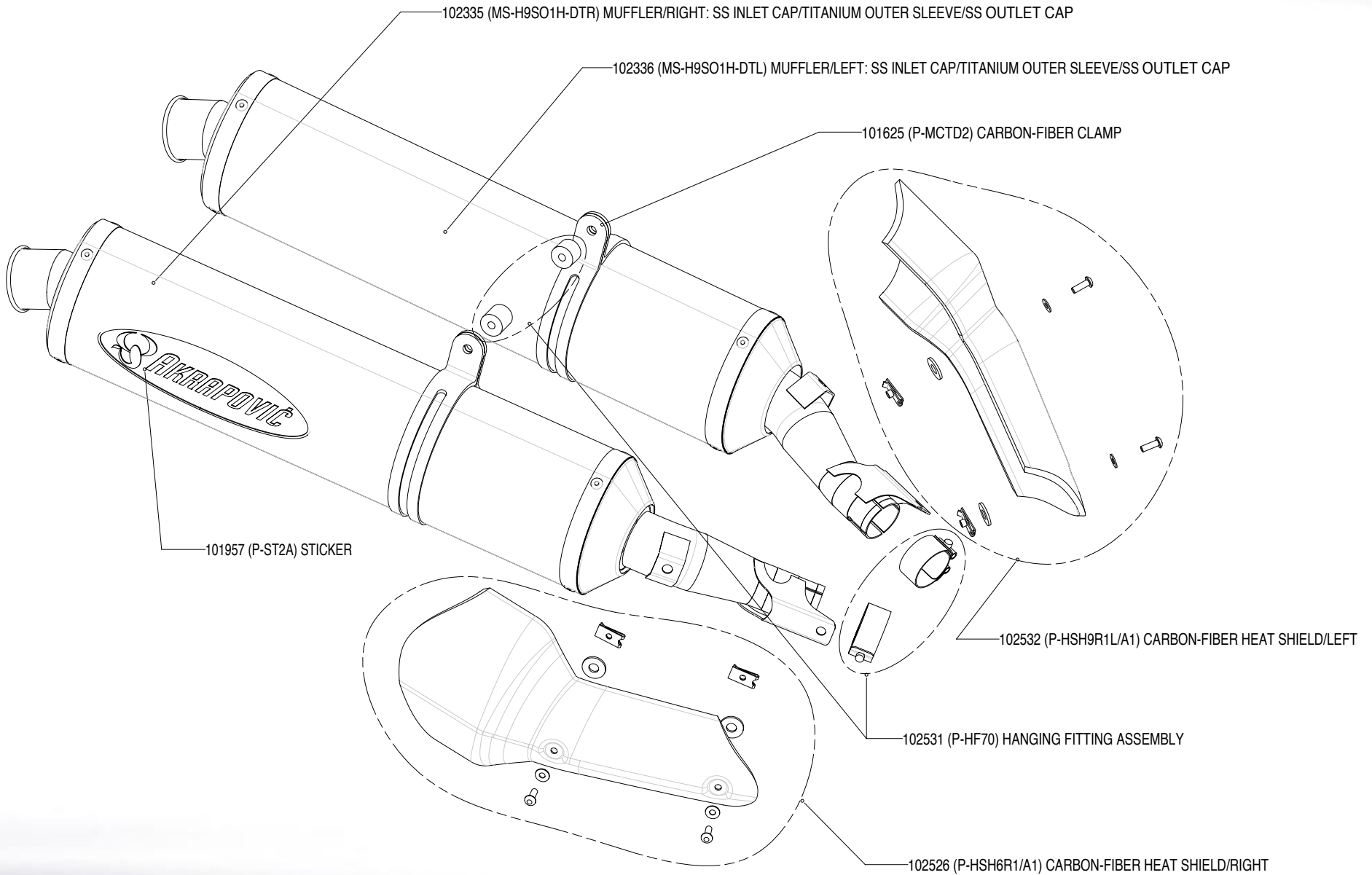

Akrapovic Exhaust System Technology copyright 2004, all rights reserved

Road Program

# Akrapovic Slip-On SP Series Exhaust System

for the Honda Hornet 900 (2002, 2003)

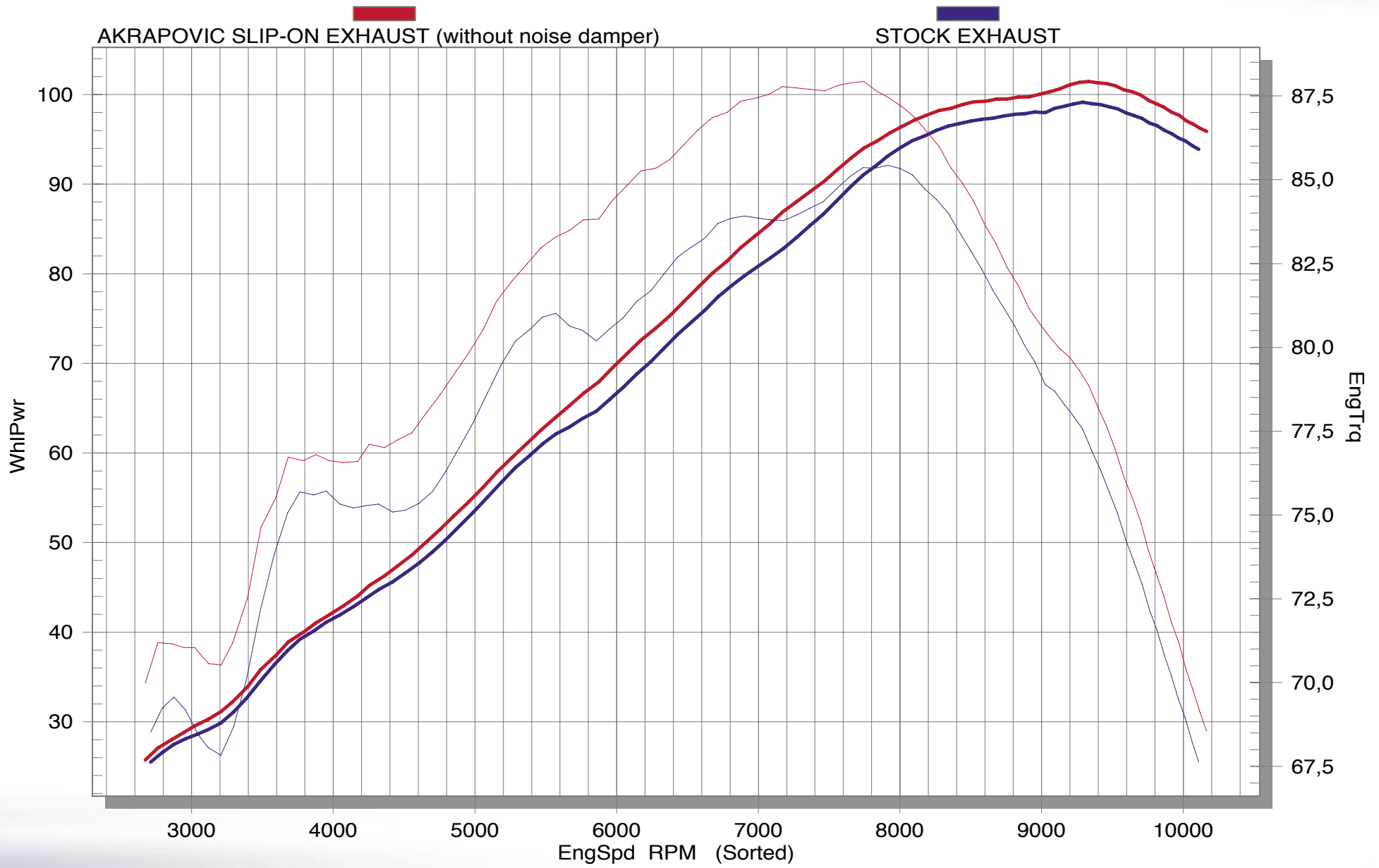

Road Program



Akrapovic Exhaust System Technology copyright 2004, all rights reserved