



Honda CB 1300 (2003)

Slip-on Exhaust System

Akrapovic Slip-On Exhaust System

for the Honda CB 1300 (2003)

Honda's legendary CB series is one of the permanent stars of the motorcycle market. Their easily recognizable design is a favorite of all fans of naked motorcycles, and produces a little bit of retro nostalgia in today's market. No matter how large the engine (although in this case the largest in the series), the CB is a package which offers all of the quality of its renowned manufacturer.

GOAL

Nice bikes always get the attention of our R&D department. Therefore this Honda has received two separate Akrapovic exhaust systems, SLIP-ON and SPORT PRODUCTION. Here we present the SLIP-ON system, which is intended for customers who do not wish to make any major modifications to the stock exhaust.

ABOUT AKRAPOVIC SLIP-ON SYSTEMS

The Akrapovic SLIP-ON exhaust system is a first-level exhaust system tuning component. One of the advantages of this system is that no modifications to the stock header tubes are necessary during installation.

It is composed of two main elements: a muffler and a link pipe. The link pipe in this case is made of high-quality stainless steel and is cylindrical in shape. The connections and attachment to the stock header tubes and the muffler are made using free-floating joints held together with high-quality silicon-shielded tensioning springs. A metal clamp is additionally used to fasten the link pipe – stock header assembly joint more securely.

The muffler is oval section, while the outer sleeve is available in either the refined metallic sheen of titanium or the black checkered pattern of carbon-fiber. In both cases, the material goes extremely well with the lines of the naked CB 1300. The choice of the material has no effect on either the performance or the tone and noise level of the sound; it is purely a matter of aesthetics.

We pay special attention to ensuring the minimal weight of our systems. Therefore all metal parts in the interior of the muffler are made exclusively of titanium.

Measurements of the Akrapovic SLIP-ON system on the Honda CB 1300:

• power:

Excellent results despite the fact that this is a first-level tuning stage. The Honda engine gets to breathe more freely, which is nicely reflected in a consistent following of the stock power curve with a noticeable improvement. At 7800 rpm the Honda delivers 115 HP to the rear wheel, a 7.7 HP increase over the stock figure.

• torque:

The torque curve is even better. Torque is increased from 2300 rpm all the way to the top of the range, while the drop-outs in the stock curve from around 4400 to 5100 rpm are filled. A massive amount of torque which allows an entire spectrum of riding styles with this motorcycle – from a relaxed style with minimal shifting to aggressively pushing the limits of the machine.

Aesthetic enhancement, improved performance, a weight savings of 3.09 kg and of course an unmistakable change in the tone of the engine, at an affordable price and simple installation with the Akrapovic SLIP-ON exhaust system.

	stock	AKRAPOVIC		difference	
		S.S.	titanium	stock - S.S.	stock - titanium
weight comparison	5.24 kg	2.15 kg	-	3.09 kg	-
max. rear wheel power	107.3 / 7700 RPM	115 HP / 7800 RPM		8.6 HP / 7900 RPM*	
noise measurement	87.2 db / 3750 RPM	94.8db / 3750 RPM		7.6 db / 3750 RPM	
legal for street use	NO				

*MAXIMUM MEASURED POWER DIFFERENCE

Technical specifications of Akrapovic exhaust systems and related products subject to change without notice.

Akrapovic Slip-On Exhaust System for the Honda CB 1300 (2003)



Akrapovic Exhaust System Technology copyright 2003, all rights reserved

Road Program

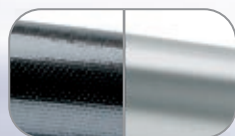

The outer sleeve is available in carbon-fiber or titanium



CARBON-FIBER
MUFFLER CLAMP

Product code: S-H13S01-T, S-H13S01-C



Akrapovic Slip-On Exhaust System for the Honda CB 1300 (2003)



Akrapovic Exhaust System Technology copyright 2003, all rights reserved

Road Program

Akrapovic Slip-On Exhaust System for the Honda CB 1300 (2003)



Akrapovic Exhaust System Technology copyright 2003, all rights reserved

Road Program

Akrapovic Slip-On Exhaust System for the Honda CB 1300 (2003)

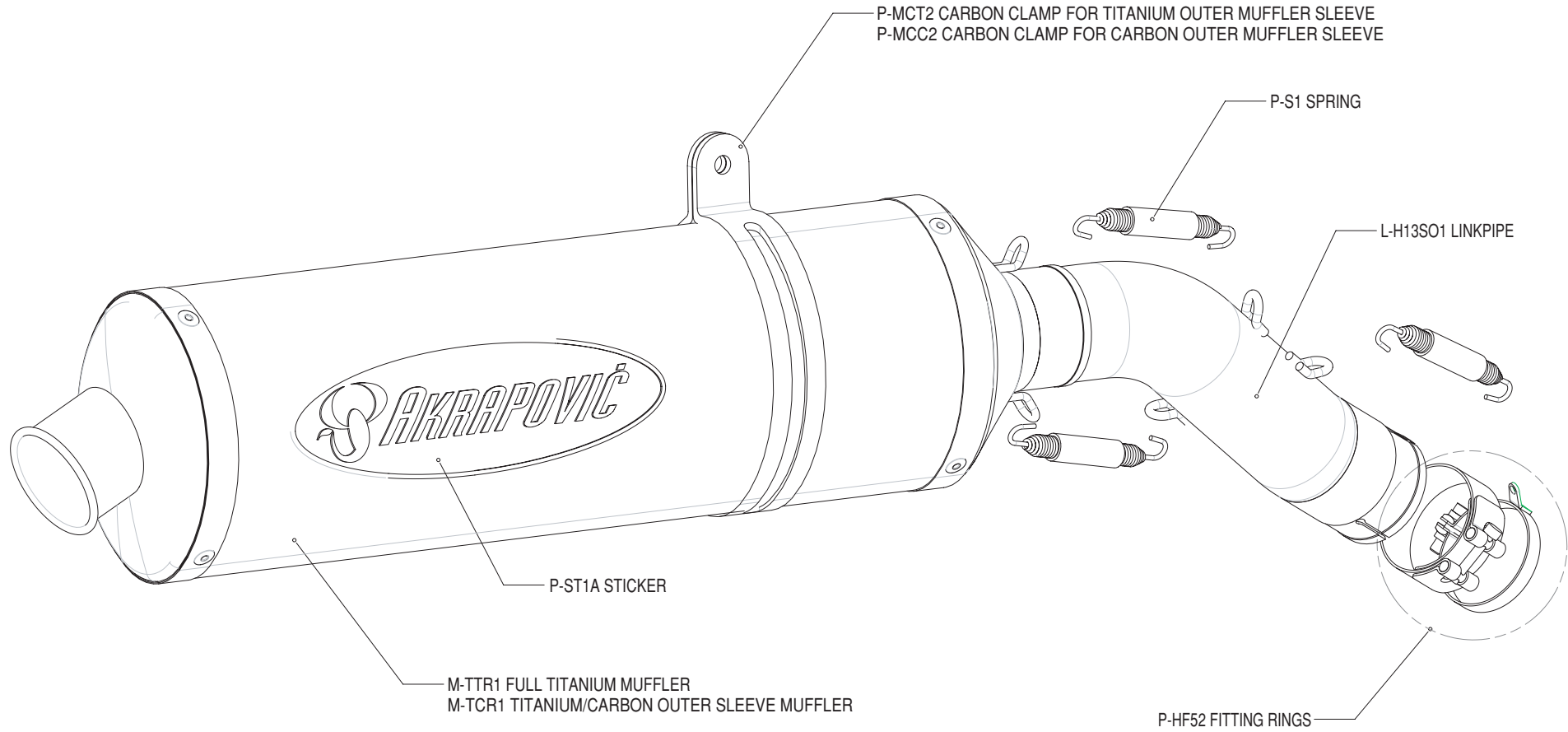

Akrapovic Exhaust System Technology copyright 2003, all rights reserved

Road Program

Product code: S-H13S01-T, S-H13S01-C



Akrapovic Slip-On Exhaust System

for the Honda CB 1300 (2003)

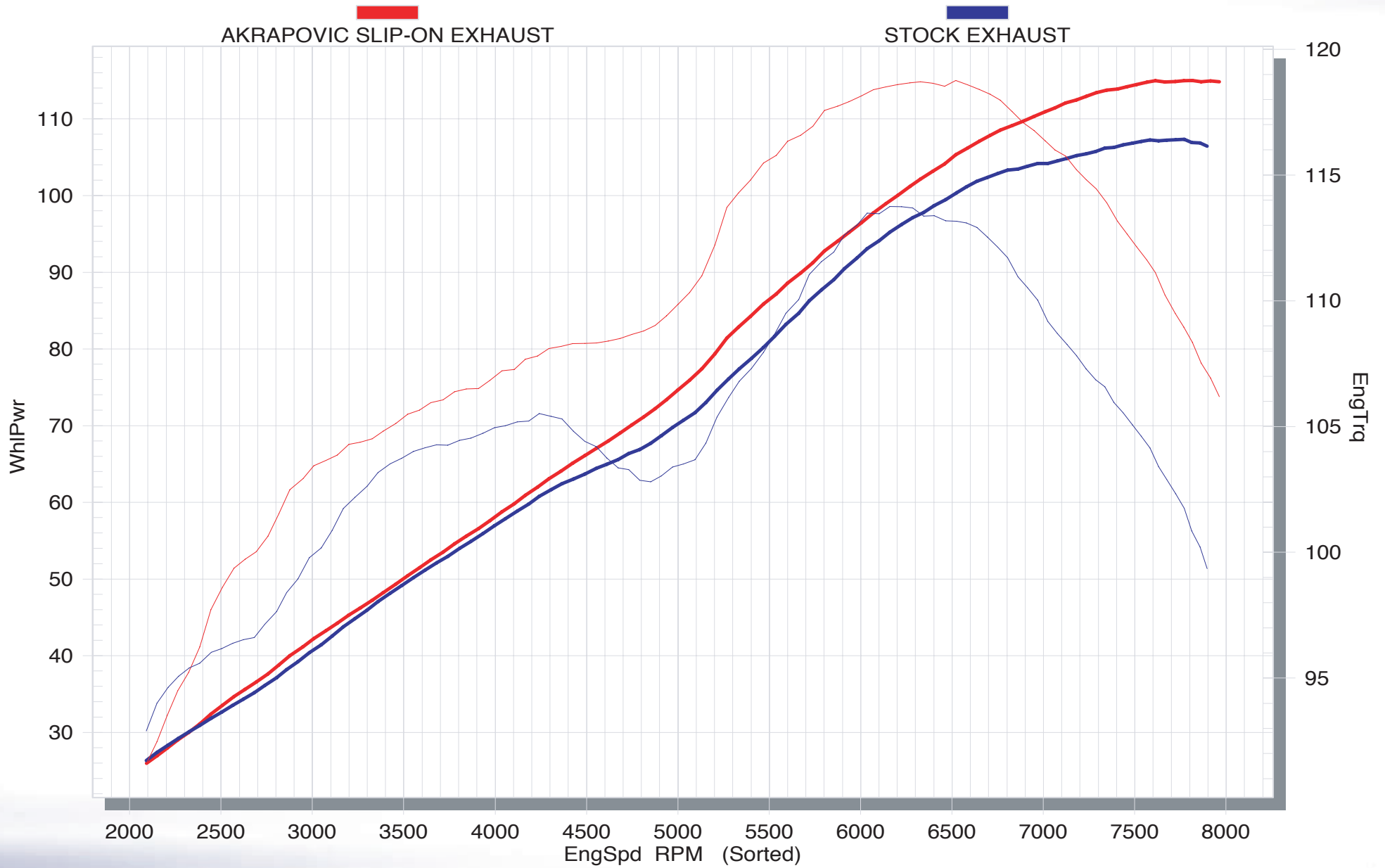

Akrapovic Exhaust System Technology copyright 2003, all rights reserved

Road Program

