



**AKRAPOVIC SLIP-ON EXHAUST SYSTEM
for the
YAMAHA YZF R1(2003)**

Congratulations on purchasing an Akrapovic exhaust system. Please read these installation instructions carefully. If you have any trouble installing the system please contact your authorized dealer!

IMPORTANT INFORMATION

Exclusion of Certain Liability

1. The manufacturer, importer or dealer shall not be liable for any incidental damage including personal injury or any other damages caused by improper installation or operation of the Akrapovic exhaust system. When installing the Akrapovic exhaust system be careful that the exhaust system does not touch other parts sensitive to high temperature.
2. Akrapovic makes no representation or warranties with regard to damage caused by the improper installation, use and maintenance of the Akrapovic exhaust system. The warranty is limited to defects recognized by our technical department and to normal use, and excludes items subject to normal wear (gaskets and damping wool). The guarantee is void in case of accident, modification, improper or competition use.
3. Do not attempt to install the Akrapovic exhaust system on a motorcycle for which it was not made or tested by Akrapovic.
4. When the exhaust system gets very hot during operation, be careful not to burn yourself on the exhaust system or parts which are in direct contact with it, even when the motor is not running. Also protect other people, especially children, from the injuries mentioned above.
5. In some cases Akrapovic exhaust system kits contain chemical products (ceramic anti-seizing grease; bolt sealant). Handle with care, do not inhale or swallow. Avoid excessive contact with skin, eyes or mucous membranes. Keep out of reach of children.
6. Technical specifications of Akrapovic exhaust systems and related products subject to change without notice.

Trademarks

The Akrapovic Exhaust System Technology logo is a registered trademark of Akrapovic d.å.

Akrpovic website

Information about Akrapovic exhaust systems and related products is available on the Akrapovic website at:
<http://www.akrapovic-exhaust.com/>

Copyright

No part of the Akrapovic exhaust system or its documentation may be reproduced or distributed in any form or by any means without the prior written authorization of the Akrapovic company.

© Akrapovic d.å. All rights reserved.

Symbols

The following symbols are used throughout this installation instructions:



INSTALLATION INSTRUCTIONS



BEFORE INSTALLING CHECK SCHEMATIC OF THE EXHAUST SYSTEM!



IN CASE THAT SOME ITEMS IN THE AKRAPOVIC EXHAUST SYSTEM PACKAGE ARE MISSING PLEASE CONTACT YOUR AUTHORIZED DEALER. KEEP THE SCHEMATIC FOR FUTURE REFERENCE.



IT IS ESSENTIAL TO READ THESE INSTALLATION INSTRUCTIONS CAREFULLY IN ORDER TO ENSURE PROPER INSTALLATION AND OPERATION OF THE AKRAPOVIC EXHAUST SYSTEM.



THE EXHAUST SYSTEM CAN BE EXTREMELY HOT. LET THE MOTORCYCLE COOL DOWN BEFORE BEGINNING INSTALLATION.



WE ADVISE YOU TO LEAVE INSTALLATION TO A QUALIFIED SERVICEMAN. IMPROPER INSTALLATION MAY RESULT IN A SHORTER LIFETIME OF THE EXHAUST SYSTEM AND/OR DAMAGE TO THE MOTORCYCLE.

REMOVAL OF STOCK EXHAUST SYSTEM

1. put the motorcycle on a side stand, we recommend a racing stand
2. remove the lower cowling (**Figure 1, 2, 3**)
3. unscrew the bolt for the metal clamp on the link pipe (at the link pipe – collector joint) (**Figure 4**)
4. unscrew and remove the bolt on the stock chassis hanging bracket and free the muffler i.e. loosen the muffler clamp (**Figure 5**)
5. remove the link pipe together with the muffler (the link pipe and muffler are welded together). We recommend spraying the joint with a multi-purpose spray lubricant (WD-40 or equivalent)
6. using a screwdriver, remove the nut in the recess of the stock muffler clamp (to be used later when attaching the Akrapovic carbon-fiber clamp) (**Figure 6, 7**)

INSTALLATION OF THE AKRAPOVIC SLIP-ON EXHAUST SYSTEM

installing the independent link pipe:

1. check the orientation of the link pipe – the tabs for attaching the springs must line up (**Figure 8**)
2. slide the link pipe (inlet side) onto the collector (**Figure 8**). If installing a titanium link pipe use ceramic anti-seizing grease in the joint
3. attach the springs (**Figure 9, 10**)
4. make sure the link pipe is not touching the frame and other parts

installing the muffler:

1. position the muffler correctly and slide it onto the outlet side of the link pipe – if installing a titanium link pipe use ceramic anti-seizing grease in the joint
2. position the springs and stretch the springs (**Figure 11**)
3. correctly position the carbon-fiber clamp and slide it onto the muffler - bear in mind the **left offset** of the carbon-fiber clamp viewed from the rear (**Figure 12, 13**). **WARNING:** open the clamp to slightly wider than the diameter of the outer sleeve of the muffler – do not scrape it along the muffler outer sleeve!
4. tighten the carbon-fiber clamp onto the stock bracket on the frame – use the stock bolts (**Figure 14**)
5. make sure the muffler is not in contact with other parts and check its alignment along the longitudinal axis of the motorcycle
6. check the position of the installed Akrapovic SLIP-ON system (**Figure 15**)

final installation:

1. tighten the bolts on all of the brackets and clamps to which the exhaust system and the other dismantled parts of the motorcycle are attached
2. clean grease spots:
 - a. muffler – titanium outer sleeve: use a soft cloth sprayed with a multi-purpose spray lubricant (WD-40 or equivalent)
 - b. muffler – carbon-fiber outer sleeve: use a soft dry cloth
 - c. stainless steel link pipe: use a soft cloth sprayed with a contact cleaner, then wipe with a soft dry cloth
 - d. titanium link pipe: use a soft cloth sprayed with a multi-purpose spray lubricant (WD-40 or equivalent)Cleaning will prevent spots from burning onto the surface. Do not use aggressive chemical cleaners, because they can damage the sticker.
3. replace all of the dismantled stock parts and cowlings in the reverse order from the order in which they were removed
4. **Check the operation of the brakes and suspension. Make sure all the bolts are sufficiently tightened. In case the exhaust system touches the cowling or other parts repeat the adjustment of the exhaust system or contact your authorized dealer.**



IT IS NORMAL IF WHITE SMOKE COMES OUT OF THE MUFFLER ON FIRST OPERATION.



DO NOT STAND BEHIND THE MUFFLER ON FIRST OPERATION.

❑ **MAINTENANCE OF THE AKRAPOVIC EXHAUST SYSTEM**

1. Clean the titanium muffler outer sleeve with a multi-purpose spray lubricant (WD-40 or equivalent) and carbon fiber outer sleeve with soft and dry cloth. Do not use aggressive chemical cleaners, because they can damage the sticker.
2. The wearing out of the muffler damping material depends on the type of the motor and riding style. Contact your dealer/serviceman if visible changes appear on muffler's outer sleeve or the noise level is increased.
3. Periodically check if all the bolts and springs are sufficiently tight.

Photos:



Figure 1



Figure 2



Figure 3

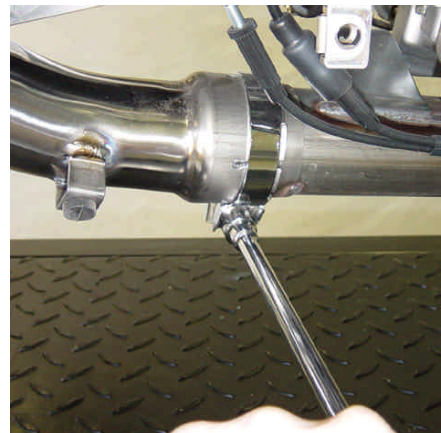

Figure 4



Figure 5

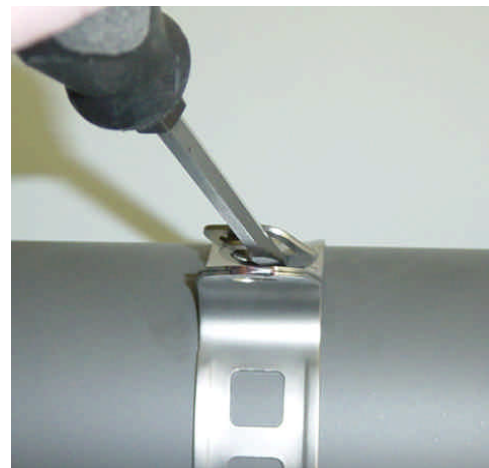

Figure 6

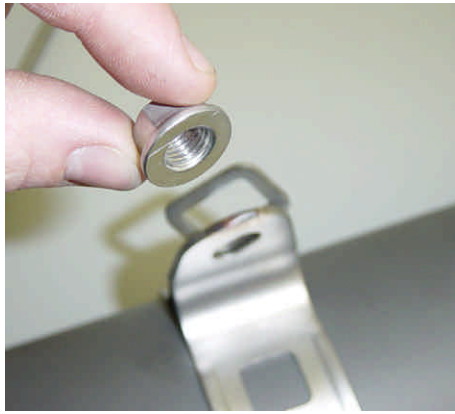

Figure 7



Figure 8



Figure 9

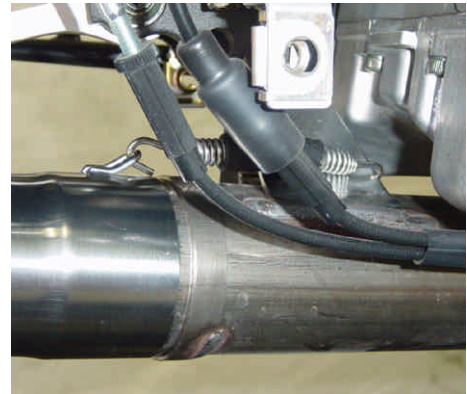

Figure 10

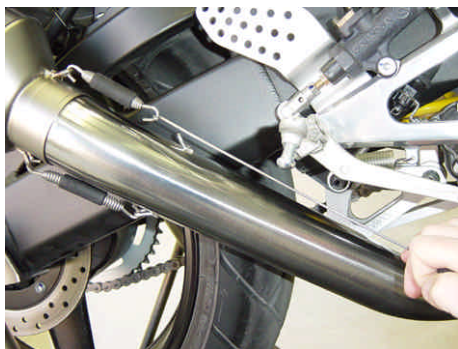

Figure 11



Figure 12



Figure 13

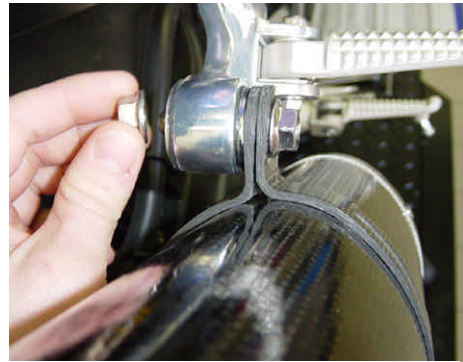
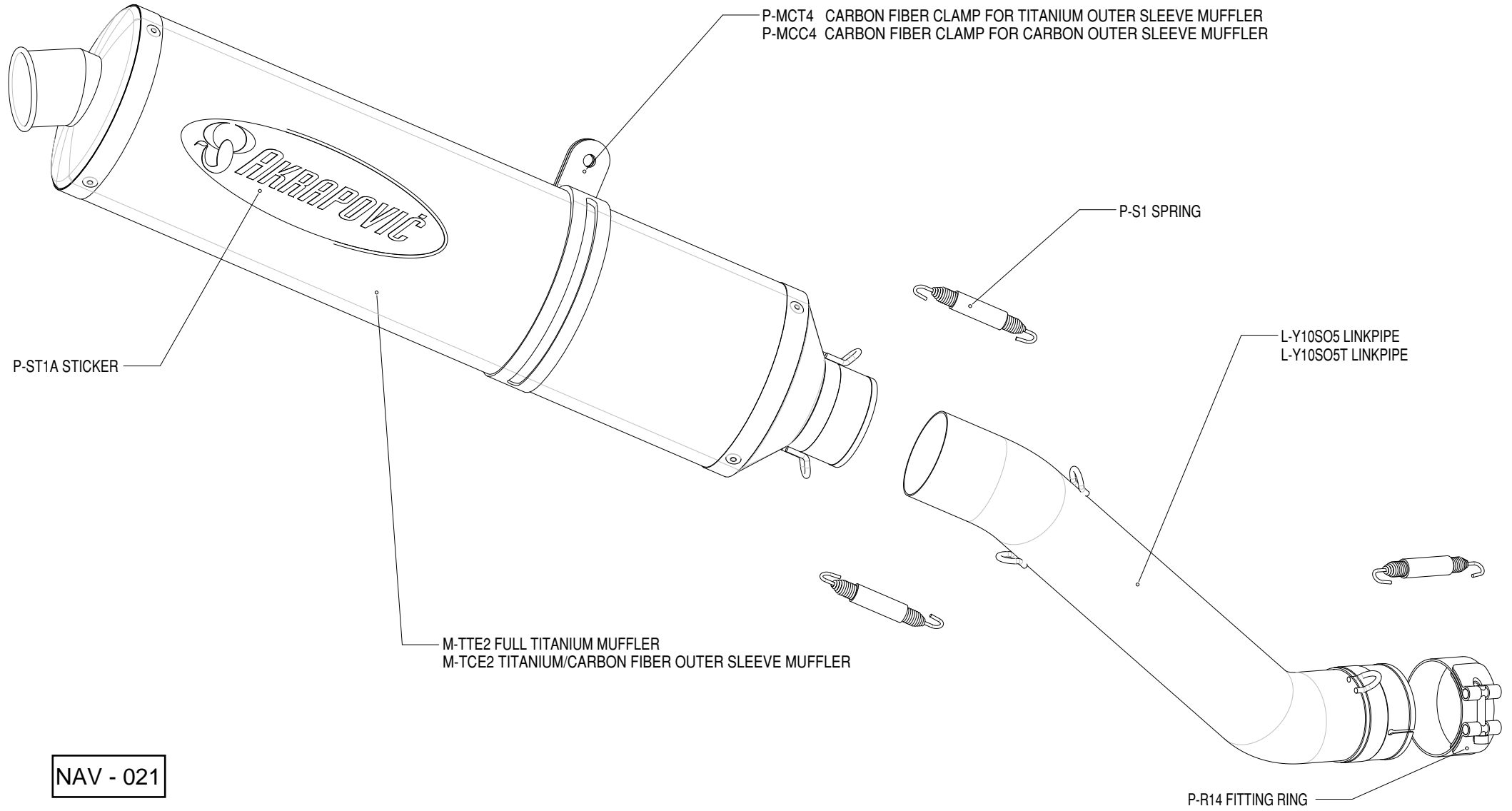

Figure 14



Figure 15



NAV - 021