



35055

Installation instructions:

AKRAPOVIC SLIP-ON EXHAUST SYSTEM for the KAWASAKI Z750(R)

Congratulations on purchasing an Akrapovic exhaust system. Please read these installation instructions carefully. If you have any trouble installing the system please contact your authorized dealer!

IMPORTANT INFORMATION

Exclusion of Certain Liability

1. The manufacturer, importer or dealer shall not be liable for any incidental damage including personal injury or any other damages caused by improper installation or operation of the Akrapovic exhaust system. When installing the Akrapovic exhaust system be careful that the exhaust system does not touch other parts sensitive to high temperature.
2. Akrapovic makes no representation or warranties with regard to damage caused by the improper installation, use and maintenance of the Akrapovic exhaust system. The warranty is limited to defects recognized by our technical department and to normal use, and excludes items subject to normal wear (gaskets and damping wool). The guarantee is void in case of accident, modification, improper or competition use.
3. Do not attempt to install the Akrapovic exhaust system on a motorcycle for which it was not made or tested by Akrapovic.
4. When the exhaust system gets very hot during operation, be careful not to burn yourself on the exhaust system or parts which are in direct contact with it, even when the motor is not running. Also protect other people, especially children, from the injuries mentioned above.
5. In some cases Akrapovic exhaust system kits contain chemical products (ceramic anti-seizing grease; bolt sealant). Handle with care, do not inhale or swallow. Avoid excessive contact with skin, eyes or mucous membranes. Keep out of reach of children.
6. Technical specifications of Akrapovic exhaust systems and related products subject to change without notice.

Trademarks

The Akrapovic Exhaust System Technology logo is a registered trademark of Akrapovic d.d.

Akrapovic website

Information about Akrapovic exhaust systems and related products is available on the Akrapovic website at:

<http://www.akrapovic.com/>

Copyright

No part of the Akrapovic exhaust system or its documentation may be reproduced or distributed in any form or by any means without the prior written authorization of the Akrapovic company.

© Akrapovic, d.d. All rights reserved.

Symbols

The following symbols are used throughout these installation instructions:



 **USE BOLT SEALANT;** Apply 3 to 4 small drops of bolt sealant onto the cleaned and degreased threads before tightening bolts. **WARNING! Avoid contact with skin, eyes and mucous membranes. Do not inhale fumes. Keep out of the reach of children.**

 **USE ANTI-SEIZING GREASE (white tube);** Prevents seizing, corrosion and excessive wear between the titanium components of your exhaust system. **WARNING! Avoid eye contact. Avoid excessive skin contact. Keep out of the reach of children.**

 **USE ANTI-SEIZE LEAD-FREE COPPER PASTE (black tube);** Provides trouble-free and long-lasting protection against seizing, corrosion and rusting of bolts, threaded ends, nuts, joints, etc. Also protects against vibration, wear and impact. **WARNING! Avoid eye contact. Avoid excessive skin contact. Keep out of the reach of children.**

INSTALLATION INSTRUCTIONS

 **BEFORE INSTALLING CHECK SCHEMATIC OF THE EXHAUST SYSTEM!**

! IF ANY ITEMS IN THE AKRAPOVIC EXHAUST SYSTEM PACKAGE ARE MISSING PLEASE CONTACT YOUR AUTHORIZED DEALER. KEEP THE SCHEMATIC FOR FUTURE REFERENCE.

! THESE INSTALLATION INSTRUCTIONS MUST BE READ CAREFULLY IN ORDER TO ENSURE PROPER INSTALLATION AND OPERATION OF THE AKRAPOVIC EXHAUST SYSTEM.

! THE EXHAUST SYSTEM CAN BE EXTREMELY HOT. ALLOW THE MOTORCYCLE TO COOL DOWN BEFORE BEGINNING INSTALLATION.

 **WE ADVISE YOU TO LEAVE INSTALLATION TO A QUALIFIED SERVICEMAN. IMPROPER INSTALLATION MAY RESULT IN A SHORTER LIFETIME OF THE EXHAUST SYSTEM AND/OR DAMAGE TO THE MOTORCYCLE.**



T-handle 10mm wrench
T-handle 12mm wrench
T-handle 13mm wrench
T-handle 14mm wrench
T-handle 4mm three hexagon key wrench
T-handle 5mm three hexagon key wrench
Combination 10mm wrench
Combination 12mm wrench
Combination 13mm wrench
Combination 17mm wrench
Screwdriver for headless slotted screws
Spring puller

REMOVAL OF STOCK EXHAUST SYSTEM:

1. Put the motorcycle on a side stand, we recommend a racing stand. Make sure, that surface is solid and flat.
2. Unscrew the bolt from the metal clamp at the muffler - collector joint, the bolt from the link-pipe bracket and muffler sub-frame bracket. Partially remove the muffler so, that you can access the exhaust valve (**Figure 1, 2, 3, 4**).



Figure 1



Figure 2



Figure 3



Figure 4

3. **For Akrapovič Slip-on without exhaust valve only:** Unscrew the exhaust valve cover and cables from the muffler (Figure 5, 6, 7, 8). Remove the muffler with link-pipe (Figure 9). Unscrew the left injection cover and fuel-tank side panel (Figure 10, 11). Remove the safety pin from the exhaust valve servo motor and completely remove the cables from the motorcycle (Figure 12, 13, 14). **WARNING: do not turn the servo motor wheel with force (only by ignition key switching!) or the servo motor could be damaged. WARNING: do not disconnect the electrical installation of the servo motor!** Reinstall the injection cover and fuel-tank side panel in the reverse order from the order in which they were removed.



Figure 5



Figure 6



Figure 7



Figure 8



Figure 9



Figure 10



Figure 11



Figure 12



Figure 13



Figure 14

4. For Akrapovič Slip-on with exhaust valve only: Shorten the cable adjusters as shown (Figure 15). Unscrew the exhaust valve cover and cables from the muffler (16, 17). Remove the muffler (Figure 18).



Figure 15



Figure 16



Figure 17



Figure 18

INSTALLATION OF THE AKRAPOVIČ SLIP-ON EXHAUST SYSTEM:

1. Slide the link pipe into the stock collector and hand tighten the bolt of link-pipe bracket (Figure 19, 20).



Figure 19



Figure 20

2. **For Akrapovič Slip-on with exhaust valve only:** Attach the stock cables to the exhaust valve as shown (Figure 21). Tighten the stock exhaust valve cover, using stock bolts (Figure 22). Adjust the adjuster with **black nut** to 5mm and the one with **bright nut** to 9mm (Figure 23). **WARNING:** be precise at adjusting the cables, or the exhaust valve won't work properly!

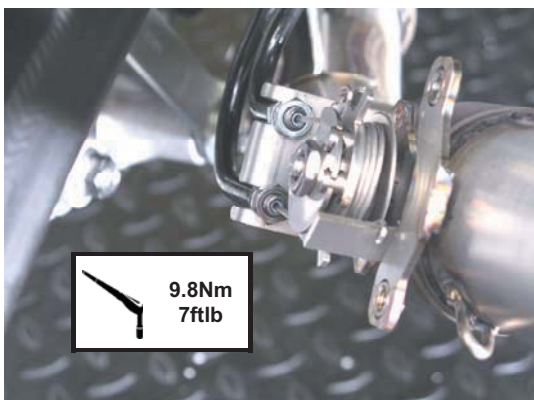

Figure 21



Figure 22

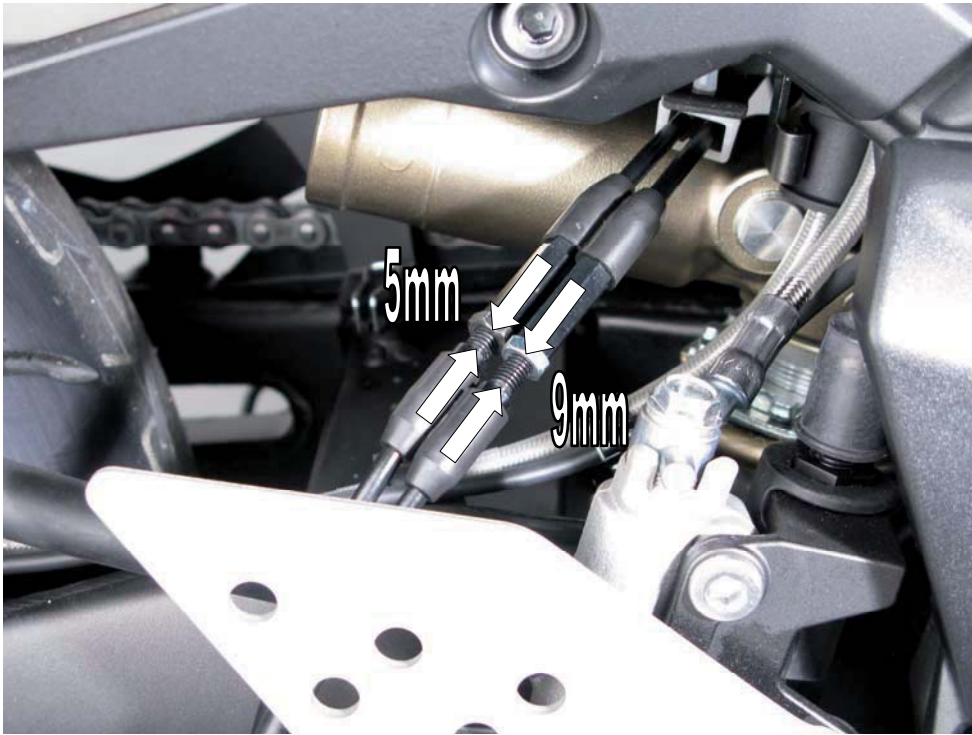

Figure 23

3. Position the muffler correctly, slide it onto the outlet side of the link pipe and attach the spring (Figure 24, 25). Correctly position the carbon-fiber clamp and slide it onto the muffler - bear in mind the left offset of the carbon-fiber clamp viewed from the rear. **WARNING: open the clamp to slightly wider than the diameter of the outer sleeve of the muffler – do not scrape it along the muffler outer sleeve!** (Figure 26). Align the muffler in respect to the motorcycle and tighten the bolt on the carbon-fiber clamp/stock muffler bracket joint (Figure 27). Tighten the link-pipe onto the stock bracket and stock metal clamp (Figure 28, 29). Make sure the link pipe or muffler are not touching the frame and other parts.



Figure 24



Figure 25



Figure 26

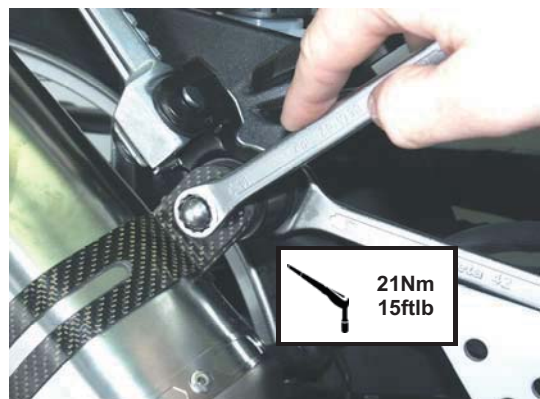

Figure 27

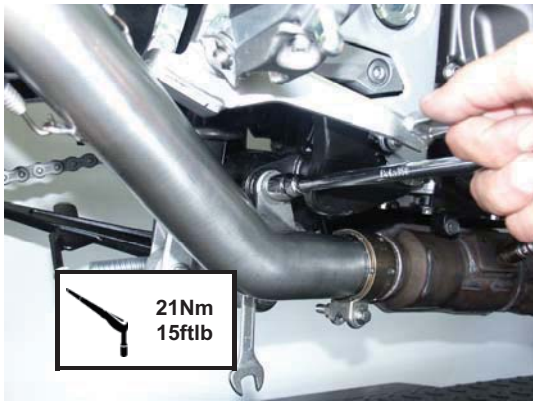

Figure 28

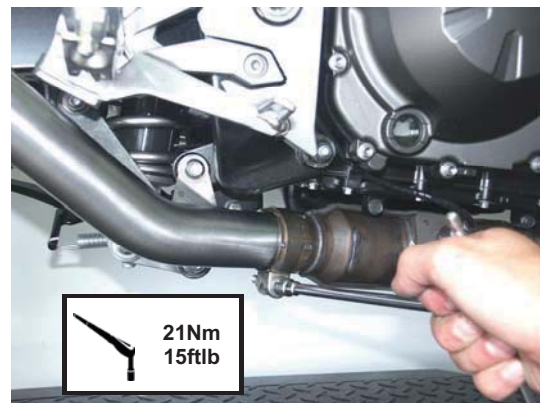

Figure 29

Final installation:

1. Clean grease spots:
 - a. Muffler – carbon-fiber outer sleeve: use a soft dry cloth.
 - b. Muffler – titanium outer sleeve: use a soft cloth sprayed with a multi-purpose spray lubricant (WD-40 or equivalent).
 - c. Muffler – carbon-fiber outlet cap: use a soft dry cloth.
 - d. Stainless steel link pipe: use a soft cloth sprayed with a contact cleaner, then wipe with a soft dry cloth

Cleaning will prevent spots from burning onto the surface. Do not use aggressive chemical cleaners, because they can damage the sticker.

Position of the correctly installed Akrapovic **SLIP-ON** systems (Figure 30, 31).



Figure 30



Figure 31

2. Check the operation of the brakes and suspension. Make sure all the bolts are sufficiently tightened. In case the exhaust system touches the cowling or other parts repeat the adjustment of the exhaust system or contact your authorized dealer.

! IT IS NORMAL IF WHITE SMOKE COMES OUT OF THE MUFFLER ON FIRST OPERATION.

! DO NOT STAND BEHIND THE MUFFLER ON FIRST OPERATION.

! DO NOT USE AUTOMOTIVE WHEEL CLEANERS OR ANY CLEANING PRODUCTS WHICH CONTAIN ACIDIC ADDITIVES TO CLEAN AKRAPOVIC EXHAUST SYSTEMS.

MAINTENANCE OF THE AKRAPOVIC EXHAUST SYSTEM

1. Clean the titanium exhaust components with a multi-purpose spray lubricant (WD-40 or equivalent), carbon fiber exhaust components with soft and dry cloth and stainless steel components with soft cloth sprayed with contact cleaner, then wipe with soft and dry cloth. Do not use aggressive chemical cleaners, because they can damage the sticker. A change in the color of the exhaust system is normal due to the high temperatures.
2. The wearing out of the muffler silencing material depends on the type of the engine and riding style. Contact your dealer/serviceman if visible changes appear on muffler's outer sleeve or the noise level is increased.
3. Periodically make sure all the bolts and springs are sufficiently tight.

KAWASAKI Z750/ SLIP ON exhaust system, model year: 2007 - 2010

Product code: S-K7SO2-ZT
S-K7SO2-ZC

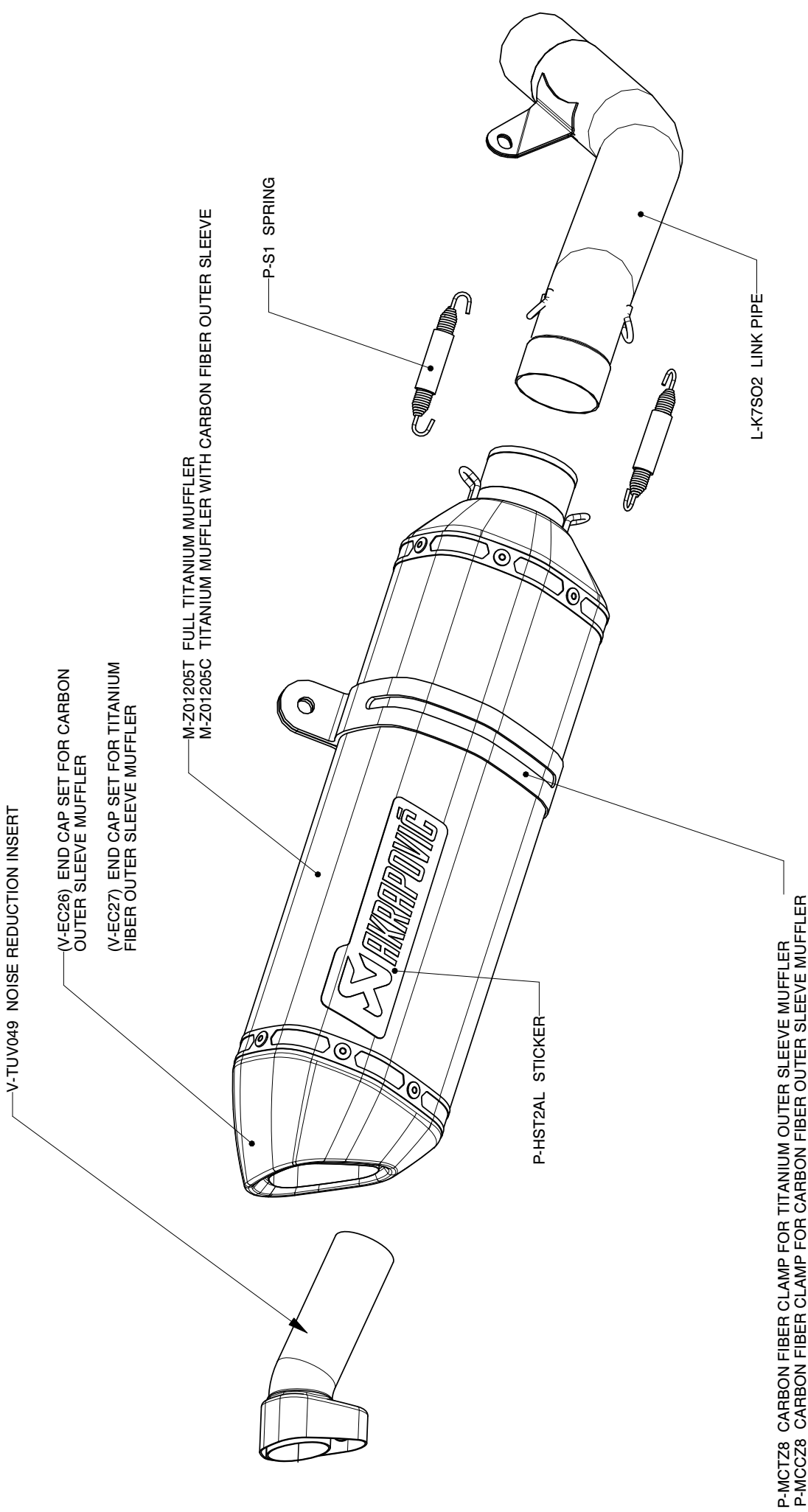

KAWASAKI Z750/ SLIP ON LINE STREET LEGAL, model year: 2007 - 2010

Product code: S-K7SO2C-HZT

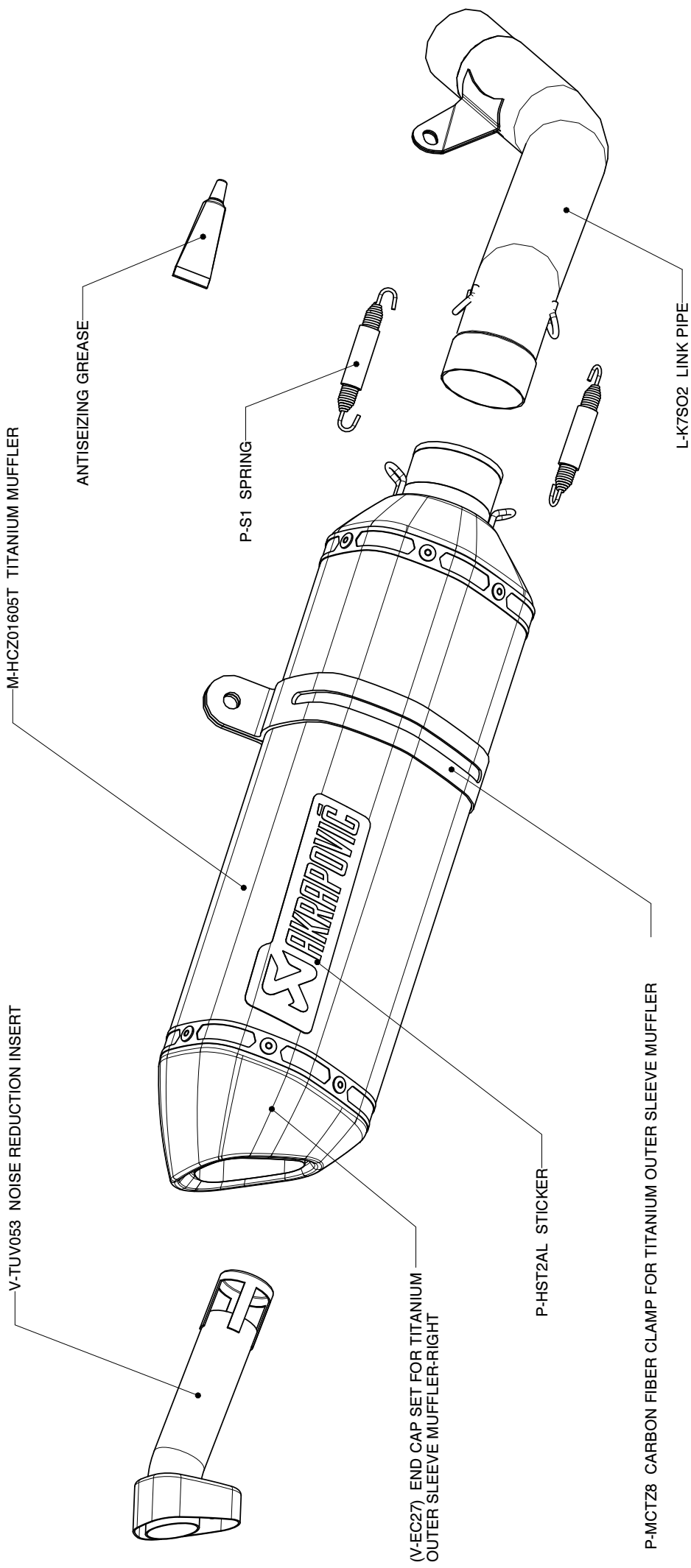

KAWASAKI Z750/ SLIP ON LINE STREET LEGAL (STIANLESS STEEL VERSION),
model year: 2007 - 2010

Product code: S-K7SO3-HZT

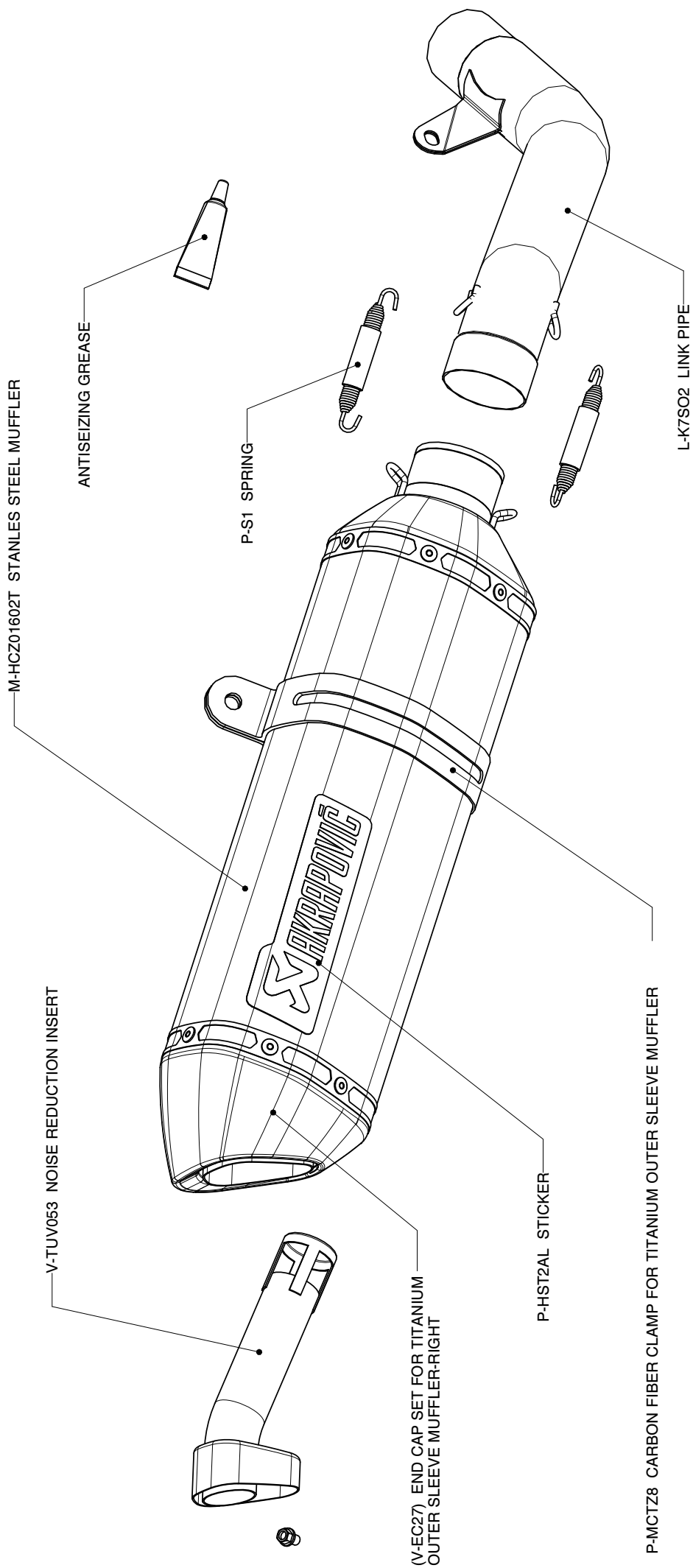

KAWASAKI Z750 / Complete exhaust system / RACING LINE tube set with Street legal SLIP on Mufflers,
Model year: 2007 - 2010

Product code: S-K7R3-ZT/1

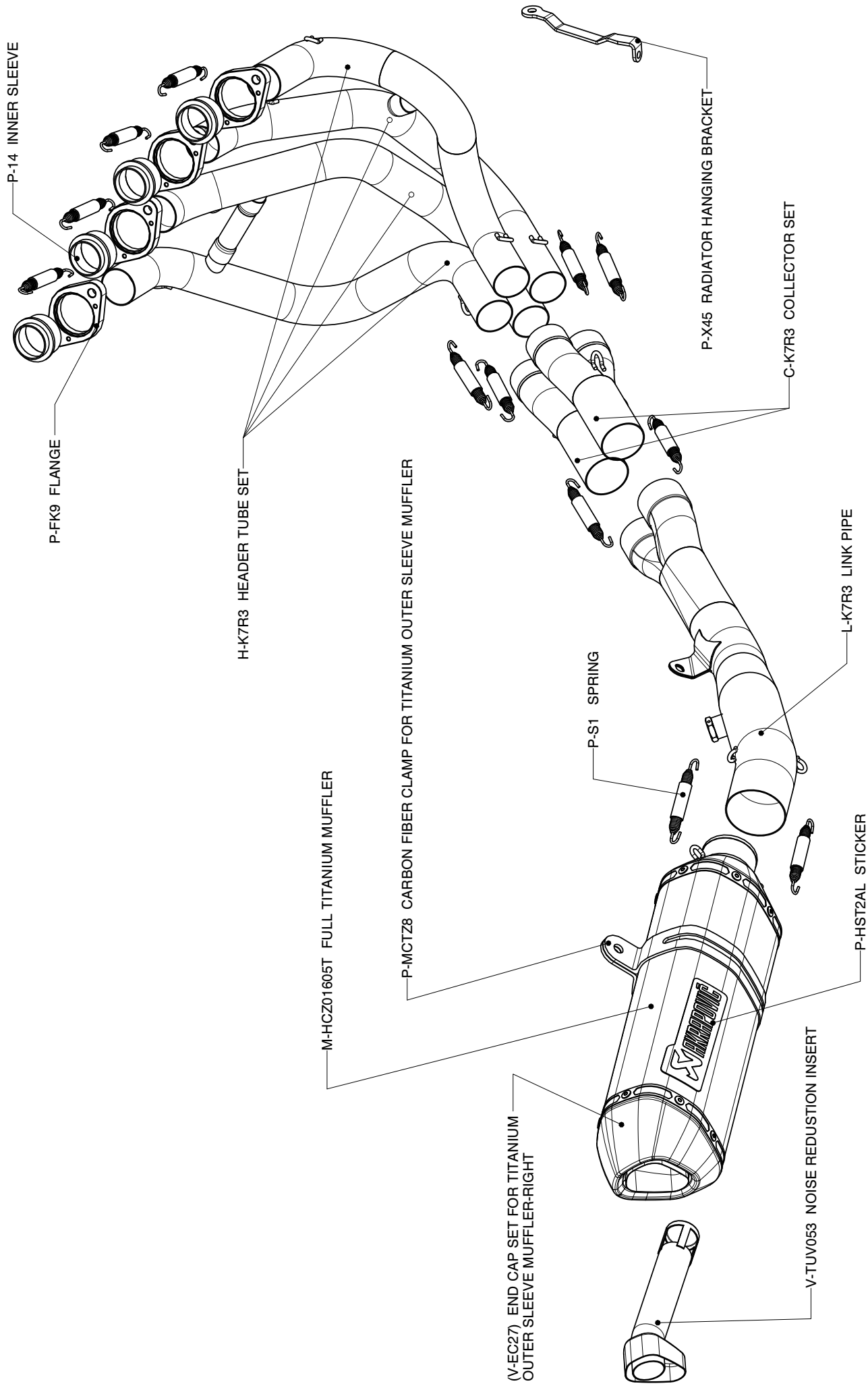

KAWASAKI Z750 / SLIP ON exhaust system / STREET LEGAL KAWASAKI Z750R

Product code: S-K7SO4-HZT

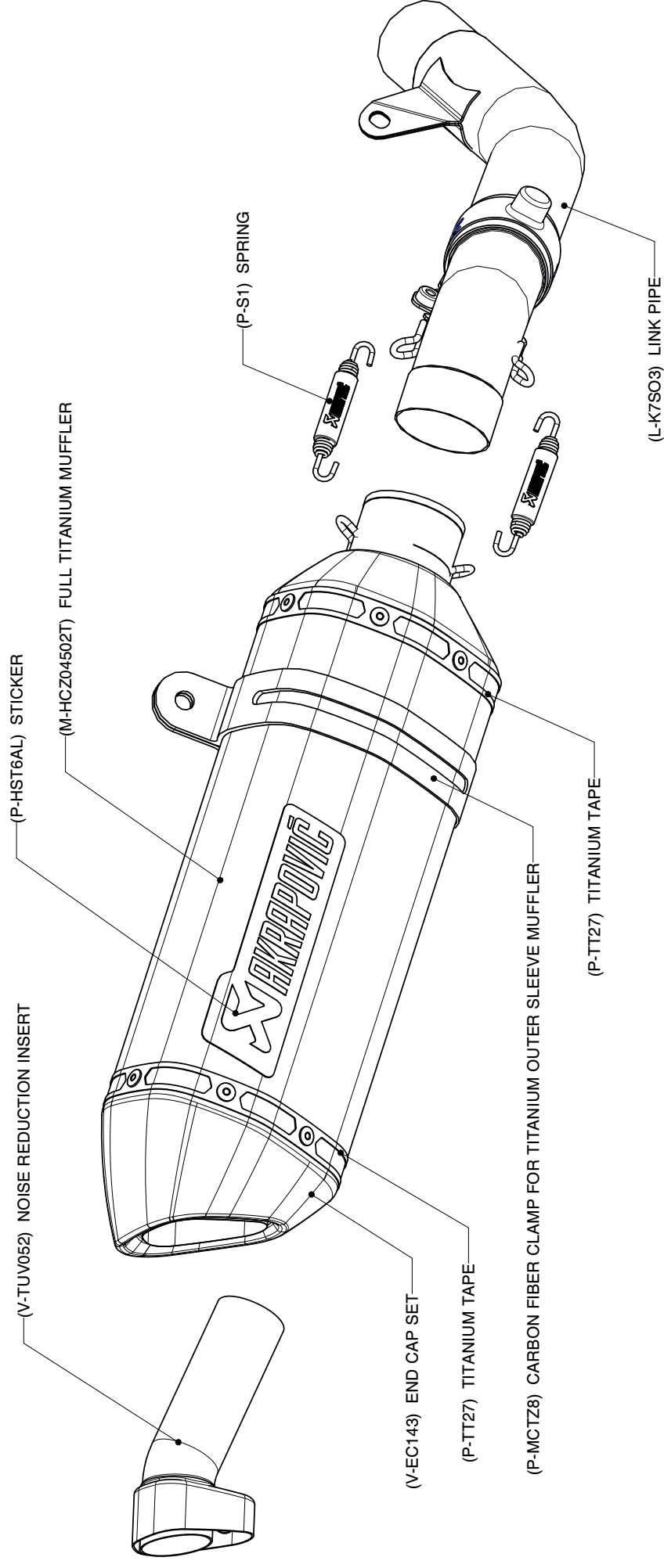

MUFFLER REPAIR KITS	
KIT	Part Nr.
REPACK	P-RPCK42
SLEEVE	P-RKS302ZT30