



Husqvarna TE 250 (2004)

Slip-On Exhaust System

Akrapovic Slip-On Exhaust System

for the Husqvarna TE 250 (2004)

The changes which were made for Husqvarna's centennial extend to their entire range of motorcycles. The exterior graphics are the most noticeable, with the number 100 proudly announcing the anniversary. Of course the changes also extend to the technical level, the popular 250 cc class being no exception.

GOAL

The entry of four-stroke machines into the 125 cc motocross racing scene is also being reflected in other off-road classes. The popularity of the 250 cc class is growing, and our R&D department is keeping up with the trend. For recreational enduro riders we have developed an Akrapovic SLIP-ON exhaust system for the Husqvarna TE 250.

ABOUT AKRAPOVIC SLIP-ON SYSTEMS

Like the system for the TE 450, the version for the 250 was developed in order to conform to FIM enduro regulations on exhaust system noise levels. We were allowed a maximum of 94 dB. Therefore we have developed a muffler with a built-in noise damper which can be removed as determined by the type of competition and individual race requirements.

The muffler for the Akrapovic SLIP-ON system is the familiar oval offroad shape, available only in titanium. All metal parts on the inside of the muffler are also of titanium. The same goes for the very short link pipe, which is welded to the front rosette of the muffler. The link pipe is attached at the other end to the stock header assembly with a free-floating joint held together with high-quality silicon-shielded tensioning springs.

NOTE:

NOTE: the Akrapovic SLIP-ON exhaust system for the 2004 HUSQVARNA TE 250 conforms to the FIM ENDURO regulations on exhaust system noise levels and is therefore intended for ENDURO competition.

Technical specifications of Akrapovic exhaust systems and related products subject to change without notice.

Unwanted movement of the muffler is restricted with the help of one double and one single Akrapovic carbon-fiber clamps which are ideally suited to their task.

Measurements of the Akrapovic SLIP-ON exhaust system on the Husqvarna TE 250 (with the noise damper installed):

• power

the small displacement of the engine is reflected in the power curve, which shows it revving happily at high revs as well. With our exhaust system, the power output at the top of the range is even higher. The increase can already be seen also in the middle of the range between 6200 and 7600 rpm, while in other areas the curve is close to the stock output. This indicates that the system complements the engine well, and offers more power in the places you need it most. At 12400 rpm the rear wheel receives 32.5 HP.

• torque

the torque curve is a sheer delight. The increase can be seen throughout nearly the entire range, which is all the more welcome since small engines are not generally known for their high torque output. Therefore in addition to the increased power, the extra torque will contribute to more dynamic enduro performance.

The use of high-quality materials such as titanium guarantees the maximum weight savings, which is extremely important in off-road motorcycling. And of course there is always an aesthetic bonus from installing an Akrapovic exhaust system. It will be immediately apparent that you have performed some basic tuning of your exhaust system.

	stock	AKRAPOVIC		difference	
		S.S.	titanium	stock - S.S.	stock - titanium
weight comparison	2.22 kg	2.02 kg		0.20 kg	
max. rear wheel power	31.5 HP / 12500 RPM	32.5 HP / 12400 RPM		1.1 HP / 12300 RPM*	
noise measurement	93.7 db / 5500 RPM	93 db / 5500 RPM		0.7 db / 4500 RPM	
periodic service possibilities without taking off A. E. S.	oil		oil filter		
	YES		YES		
legal for street use	NO				

*MAXIMUM MEASURED POWER DIFFERENCE

Akrapovic Slip-On Exhaust System for the Husqvarna TE 250 (2004)



CARBON-FIBER
MUFFLER CLAMPS

Off-Road
Program

Product code: S-HU2S01-MT



Akrapovic Exhaust System Technology copyright 2003, all rights reserved

Akrapovic Slip-On Exhaust System for the Husqvarna TE 250 (2004)



Akrapovic Exhaust System Technology copyright 2003, all rights reserved

Off-Road
Program



Akrapovic Slip-On Exhaust System for the Husqvarna TE 250 (2004)



Akrapovic Exhaust System Technology copyright 2003, all rights reserved

Off-Road
Program

Product code: S-HU2S01-MT



Akrapovic Slip-On Exhaust System for the Husqvarna TE 250 (2004)

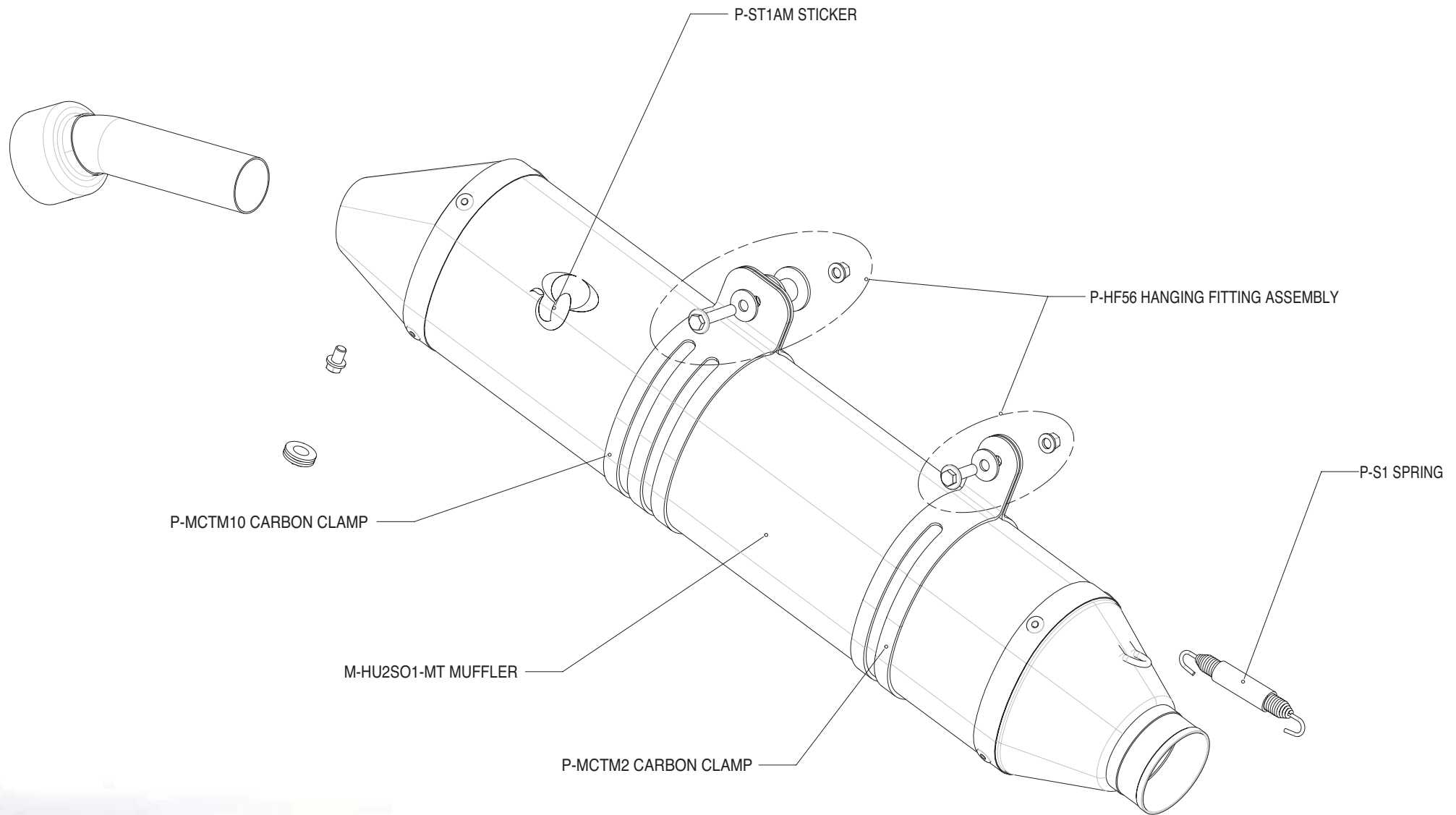

Akrapovic Exhaust System Technology copyright 2003, all rights reserved

Off-Road
Program



Akrapovic Slip-On Exhaust System for the Husqvarna TE 250 (2004)

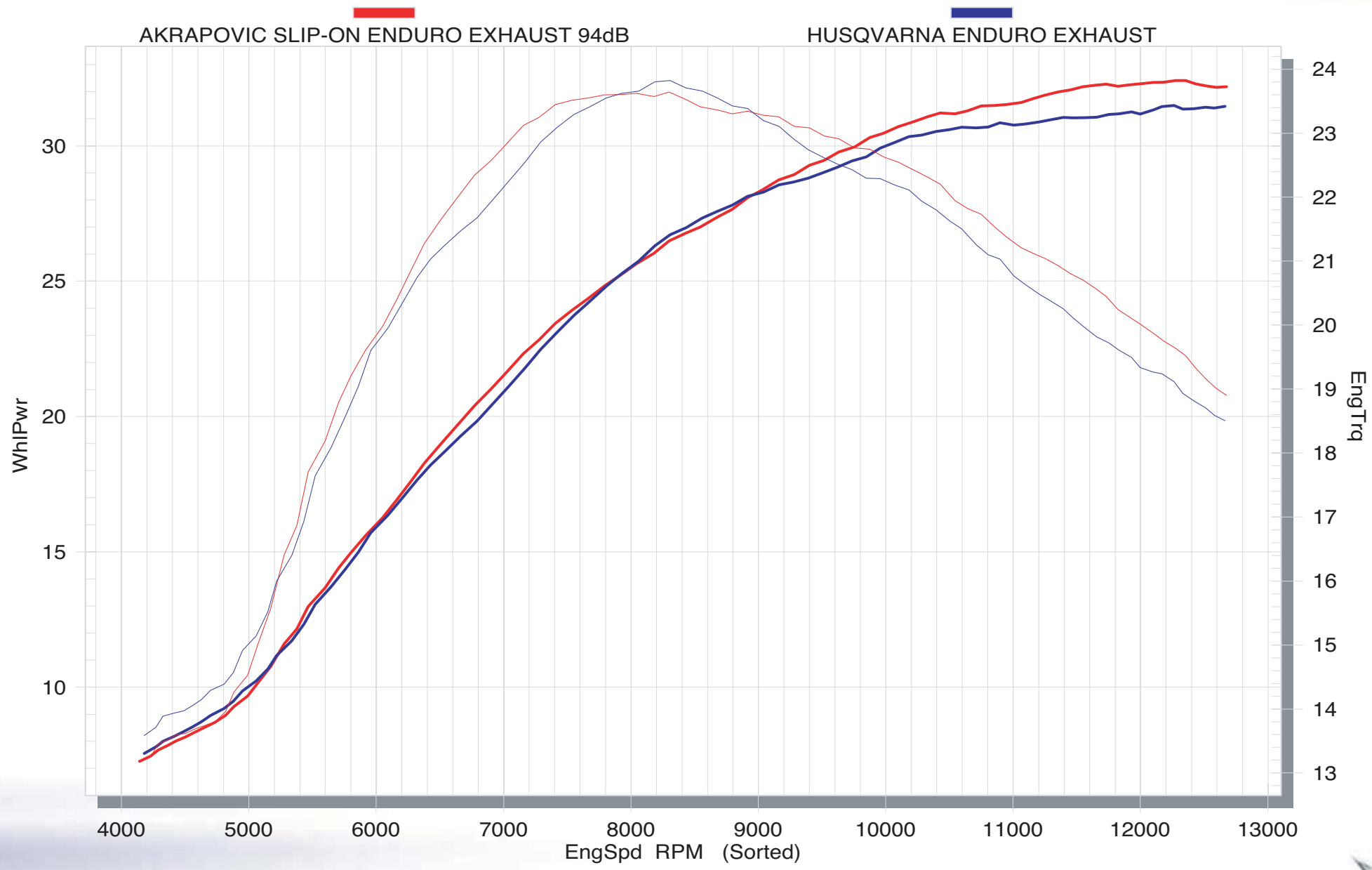

Off-Road Program

Akrapovic Exhaust System Technology copyright 2003, all rights reserved

